

OPERATOR'S MANUAL

SUPPLEMENT

Model No. 714 – 4.0HP Indy Kar

715 – 5.0HP Indy Kar

⚠ WARNING:

Read Engine Owner's Manual, Vehicle Operator's Manual, and Supplement Carefully Before Operating Vehicle.

Parts List



4404 Engle Ridge Drive, Fort Wayne, IN 46804

ph (260) 432-1596

fx (260) 432-7870

**THIS VEHICLE IS FOR
OFF-ROAD USE ONLY**

BEFORE OPERATING THIS VEHICLE, THE OWNER AND/OR OPERATOR MUST UNDERSTAND THE VEHICLE WAS NOT DESIGNED OR MANUFACTURED TO MEET SPECIFICATIONS FOR USE ON STREETS, HIGHWAYS, OR THOROUGHFARES AND HAVE READ AND HAVE AN UNDERSTANDING OF ALL THE INSTRUCTIONS FOR SAFE ASSEMBLY AND OPERATION AS WELL AS THE INSTRUCTIONS GOVERNING THE ENGINE AND OTHER PORTIONS OF THE VEHICLE.

PARTS LIST FOR 4HP & 5HP INDY KARS

REF	PART #	DESCRIPTION
1	5297-2	FRAME - BLACK
2	12246 12247	ENGINE - 4HP ROBIN ENGINE - 5HP ROBIN
3	4399-2	SEAT FRAME - BLACK
4	1976	SEAT
5	1398	WASHER 21/64ID X 1-1/4 X 1/8
ASM	4195	5HP CLUTCH ASSY - INCLUDES 6 - 10
ASM	4335	4HP CLUTCH ASSY - INCLUSED 6 - 10
6	4496	CLUTCH CENTER - SGL SPROCKET
7	3146	FIBER WASHER
8	9781 4491	DRUM W/SPROCKET FOR 5HP MODEL DRUM W/SPROCKET FOR 4HP MODEL (BOTH INCLUDE #9)
9	3143	BEARING
10	3141	SNAP RING
11	8409	NUT 1/2-20 HEX ZINC
12	1491	BOLT 5/16-24 X .750 HHCS G5
13	9149	PUSH NUT 1/4
14	9150	PUSH NUT 1/2
15	3463	WASHER 1/4 RUBBER
16	9101	BOLT 5/16-24 X .500 HHCS G5 NYLOCK
17	9569 8927	COVER - 5HP MODEL COVER - 4 HP MODEL
18	1194	WASHER 3/4 SAE FLAT ZINC
19	1124	WASHER 5/16 SL ZINC
20	9186	BOLT 5/16-18 X 1.500 HHCS G5 ZINC
21	1046	NUT 5/8-11 TOPLOCK HEX ZINC
ASM	11607	5HP DRIVE WHEEL ASSY - 5IN STEEL (INLCUDES 24, 25, 32, 34, 35, 37 - 39)
ASM	11608	4HP DRIVE WHEEL ASSY - 5IN STEEL (INLCLUDES 11, 24, 25, 32 - 35, 37, 38)
22	5090	BEARING 5/8ID X 1-3/8OD SNAP RING
23	10374	WH ASM 5IN STL SLK (INCLUDES 30 & 31)
24	10375	WH ASM 5IN STL DR WH 4.10 X 3.50 SLK
25	9085	NUT 3/8-16 TOPLOCK HEX Z
26	10373	WH ASM 4IN STL SLK (INCLUDES 27 & 28)
27	1053	TUBE 4.10/3.50 X 4
28	1751	TIRE 4.10/3.50 X 4 SLICK
29	8933-2	COVER PANEL - BLACK
30	1753	TUBE 4.10/3.50 X 5
31	6035	TIRE 4.10/3.50 X 5 SLICK
32	9169	NUT 1/2-20 HEX JAM ZINC (4 per 4HP, 8 per 5HP)
33	8186	WASHER .391ID X 1.25OD X .12 (4HP MODEL)
34	8007 9493	SPROCKET SA 35P 60T (4HP MODEL) SPROCKET SA 420P 60T (5HP MODEL)
35	9091	WASHER FLAT 3/8 SAE N ZINC
37	1246-16	BRAKE DRUM 4IN - ZINC
38	9158 9145	BOLT 3/8-16 X 2.25 HHCS G5 (4HP MODEL) BOLT 3/8-16 X 1.75 HHCS G5 (5HP MODEL)
39	9169	NUT 1/2-20 HEX JAM ZINC
ASM	6982	TIE ROD ASSEMBLY (INCLUDES 40 - 44)
40	9092	NUT 3/8-24 HEX JAM ZINC
41	1414	TIE ROD END - RIGHT THREAD
42	1415	TIE ROD END - LEFT THREAD
43	9024	NUT 3/8-24 LEFT THREAD JAM
44	6981	TIE ROD 11.25"
45	1119	SPACER .625ID 1.062OD .125 THK
46	1264	BOLT 1/2-13 X 3.75 HHCS G2 ZINC

REF	PART #	DESCRIPTION
47	1012	NUT 1/2-13 TOPLOCK HEX ZINC
48	8021-2Z	RIGHT SPINDLE WITH GREASE ZERK
NI	8020-2Z	LEFT SPINDLE WITH GREASE ZERK
49	9085	NUT 3/8-16 TOPLOCK HEX ZINC
50	BODY	SPECIFY COLOR
51	SPOILER	SPECIFY COLOR
53	9145	BOLT 3/8-16 X 1.75 HHCS G5 ZINC
54	8251	THROTTLE CABLE 74.50" (INCLUDES 55)
55	9058	NUT 5/16-24 HEX JAM ZINC
56	9057	NUT 1/4-20 TOPLOCK ZINC
58	3279-16	THROTTLE PEDAL - ZINC
59	3280-16	BRAKE PEDAL - ZINC
60	11330	DECAL SHEET - WARNINGS
62	9146	BOLT 3/8-16 X 1.50 HHCS G5 ZINC
63	1189	NUT 5/16-18 HEX TOPLOCK ZINC
64	1846	BOLT 1/4-20 X .750 HHCS G5 ZINC
65	1854	WASHER NBR 14 FLAT ZINC
66	1848	BOLT 1/4-20 X 1.25 HHCS G5 ZINC
67	1849	BOLT 1/4-20 X 1.50 HHCS G5 ZINC
68	5097-2	BRAKE ROD - BLACK
69	3288-16	SPACER .50ID X .750ID X .50L ZINC
70A	4266-16	SPACER .875OD .625ID 1.125L ZINC (4HP MODEL)
70B	1119	SPACER .625ID 1.062OD .125THK (QTY 4 - 5HP MODEL)
71	2024-16	SPACER .875OD .625ID 1.500L ZINC
72	12347	ENGINE SWIVEL SCREW
73	9116	COTTER PIN 3/32 X .750 Z
74	9118	CLEVIS PIN 1/4 X 1.250 ZINC
75	1263	NUT 5/16-18 HEX WHIZ FLANGE ZINC
76	5839	BOLT 1/4-20 X .750 HH WHIZ FLANGE ZINC
77	1036	BRAKE BAND - 4INCH
78	1019	CABLE TIE - 7INCH
ASM	9799	STOP SWITCH ASSEMBY (INCLUDES 79)
79	1392	TOGGLE SWITCH
80	9030	WASHER 5/16 IL ZINC
82	12273	WIRE HARNESS
84	5732	WASHER 1/4 IEL ZINC
85	6038	STEERING WHEEL
86	9080	BOLT 1/4-20 X 2.75 HHCS G2 ZINC
87	9160	BOLT 1/4-20 X .875 HHCS G5 NYLOCK ZINC
88	4365	SPRING EXTENSION .375OD
89	6511 9788 5295	CHAIN 420 X 66 W/MSTRLINK (5HP MDL) CHAIN 35 X 58P W/MSTRLINK (4HP MDL) CHAIN 35 X 108 W/MSTRLINK (4HP MDL)
90	2037 1269	MASTER LINK 420 MASTER LINK 35
96	1119	SPACER .625ID 1.062OD .125THK (5HP MDL)
97	3123-2	STEERING COLUMN EXTENSION - BLACK
98	12348	ENGINE RETURN SPRING
NI	6985	SEAT SLIDE KIT (5HP MODEL ONLY)
NI	8778	SEAT BELT (5HP MODEL ONLY)

NI = NOT ILLUSTRATED

ASM = ASSEMBLY

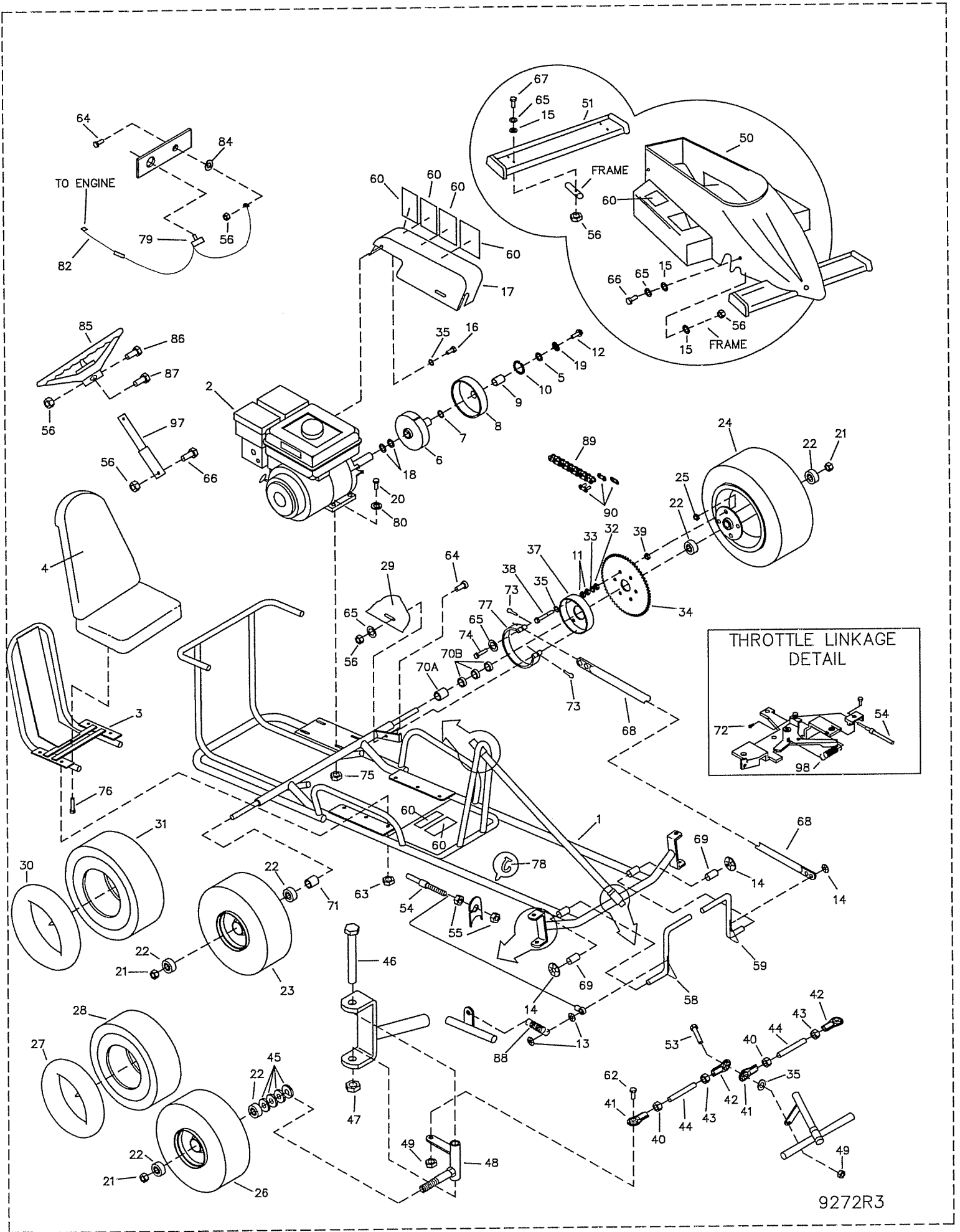

4HP MODEL ONLY

SPEED REDUCER		
REF NO	PART NO	DESCRIPTION
1	1136	NUT 5/8-18 CL HEX JAM Z
2	5090	BEARING 5/8 ID 1-3/8 OD SNAP RING
3	6568	SPANNER 5/8 ID X 3-7/8 LG 11GA
4	2385	BOLT 3/8-16 X 4.000 FULL THRD HHCS G2 Z
5	1128	NUT 3/8-16 HEX Z
6	6563	JACKSHAFT 5/8 X 8.500
7	1119	SPACER .625ID 1.062OD .125THK Z
8	6570	SPROCKET 35P 26T .625IN ID
9	1031	KEY 3/16SQ X .500L
10	4266-16	SPACER .875OD .625ID 1.125L - ZINC PLTD
11	3504	SPROCKET DR 35P 12T .625IN ID
12	6558-2	SPEED REDUCER CHASSIS GBLBK

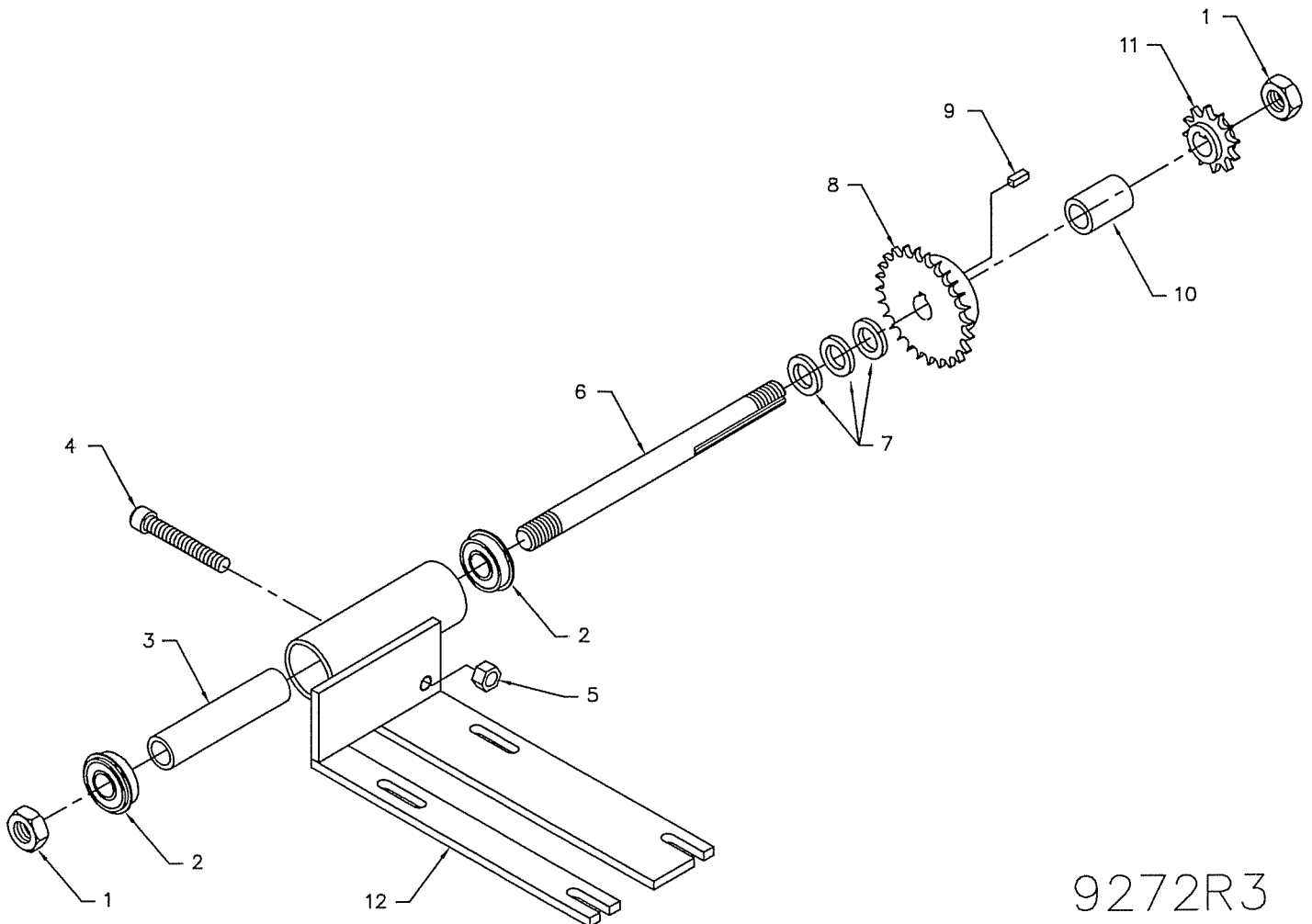

9272R3

5HP MODEL ONLY

MARCO

PowerSports

4404 Engle Ridge Drive, Fort Wayne, IN 46804
Tele: (260)432-1596 Fax: (260)432-7870

