

OPERATOR'S MANUAL

SUPPLEMENT

Model No. 616B
617C

WARNING:

Read Engine
Owner's Manual,
Vehicle Operator's
Manual, and
Supplement
Carefully Before
Operating Vehicle.

Parts List



4404 Engle Ridge Drive, Fort Wayne, IN 46804
ph (260) 432-1596 fx (260) 432-7870

**THIS VEHICLE IS FOR
OFF-ROAD USE ONLY**

BEFORE OPERATING THIS VEHICLE, THE OWNER AND/OR OPERATOR MUST UNDERSTAND THE VEHICLE WAS NOT DESIGNED OR MANUFACTURED TO MEET SPECIFICATIONS FOR USE ON STREETS, HIGHWAYS, OR THOROUGHFARES AND HAVE READ AND HAVE AN UNDERSTANDING OF ALL THE INSTRUCTIONS FOR SAFE ASSEMBLY AND OPERATION AS WELL AS THE INSTRUCTIONS GOVERNING THE ENGINE AND OTHER PORTIONS OF THE VEHICLE.

PARTS LIST MODELS 616B & 617C

REF	PART#	DESCRIPTION
1	13317-7	FRAME - LIME GREEN
	13317-13	FRAME - ORANGE
	13317-29	FRAME - ULTRAMARINE BLUE
	13317-37	FRAME - RED WAGON
	13317-40	FRAME - SILVER
2	12628-2Z	REAR SWINGARM W/ZERK
3	13319-2Z	BOTTOM SWINGARM W/ZERK - BLACK
	13319-40Z	BOTTOM SWINGARM W/ZERK - SILVER
4	13320-2Z	TOP SWINGARM W/ZERK - BLACK
	13320-40Z	TOP SWINGARM W/ZERK - SILVER
5	13259-2	FRONT BAR - BLACK
	13259-40	FRONT BAR - SILVER
6	13264-2	CENTER BAR - BLACK
	13264-7	CENTER BAR - LIME GREEN
	13264-13	CENTER BAR - ORANGE
	13264-29	CENTER BAR - ULTRAMARINE BLUE
	13264-37	CENTER BAR - RED WAGON
7	13256-2	REAR BAR - BLACK
	13256-40	REAR BAR - SILVER
8	12550-2	SEAT FRAME - BLACK
9	9022	WASHER 1/2 STD FLAT ZINC
10	13504	BOLT 1/2-13 X 1.00 HHCS G5 ZINC
11	13503	NUT 1/2-13 CENTERLOCK HEX ZINC
12	13343	BOLT 1/2-13 X 5.50 HEX HEAD G8
13	10834	BOLT 1/2-13 X 7.00 HHCS G5 ZINC
14	1046	NUT 5/8-11 TOPLOCK HEX ZINC
15	12141	SHOULDER BOLT 1/2 X 1.875
16	9125	WASHER FLAT 3/8 FLAT USS
17	13192	FRONT WHEEL ASSY 6" (INCLS 18 - 20)
18	5090	BEARING 5/8ID X 1-3/8OD SNAP RING
19	5950	SPANNER 5/8ID X 2-1/8
20	13499	TIRE - 145/70 X 6 BADLAND
21	3802	TUBE - 6 INCH (REPAIR PART ONLY)
22	13296-2	RIGHT SPINDLE - BLACK
NI	13297-2	LEFT SPINDLE - BLACK
23	13460	TIE ROD ASSY - 13" (INCLS 28, 81 - 84)
24	12655	TIE ROD ASSY - 4" (INCLS 25 - 27, 29, 30)
25	1414	RIGHT TIE ROD END 3/8-24
26	9092	NUT 3/8-24 HEX JAM - RIGHT
27	12654	TIE ROD - 4 INCH
28	13461	TIE ROD - 13 INCH
29	9024	NUT 3/8-24 JAM - LEFT
30	1415	LEFT TIE ROD END 3/8-24
31	6452	BOLT 3/8-16 X 5.00 HHCS G5 ZINC
32	9146	BOLT 3/8-16 X 1.50 HHCS G5 ZINC
33	6293-16	BRAKE PEDAL
34	6309-16	THROTTLE PEDAL
35	1189	NUT 5/16-18 TOPLOCK HEX ZINC
36	6734	SEAT SLIDE - PAIR
37	9176	BOLT 5/16-18 X 1.00 HHCS G5 ZINC
38	1447	SHOULDER BOLT 5/16-18 C 11/16 THD
39	9091	WASHER 3/8 FLAT SAE ZINC
40	9160	BOLT 1/4-20 X .875 HHCS NYLOCK G5 Z
41	1848	BOLT 1/4-20 X 1.25 HHCS G5 ZINC

REF	PART#	DESCRIPTION
42	6349	BUSHING 5/16 OD 22G
43	1846	BOLT 1/4-20 X .750 HHCS G5 ZINC
44	1847	BOLT 1/4-20 X 1.00 HHCS G5 ZINC
45	1389	BUSHING .25ID X .031G X .313
46	9502	PEDAL SPRING - LEFT WOUND
47	9503	PEDAL SPRING - RIGHT WOUND
48	1854	WASHER NBR 14 FLAT MS ZINC
49	8251	THROTTLE CABLE (INCL #50)
50	9058	NUT 5/16-24 HEX JAM ZINC
51	12347	SWIVEL SCREW
52	12348	RETURN SPRING
53	12636-2	BRAKE ROD - BLACK
54	9145	BOLT 3/8-16 X 1.75 HHCS G5 ZINC
55	9597	BRAKE CALIPER
56	12496	STEERING WHEEL
NI	12481	STEERING WHEEL DECORATIVE CAP
57	9103	BOLT 1/4-20 X 2.00 HHCS G2 ZINC
58	9057	NUT 1/4-20 TOPLOCK HEX ZINC
59	6511	CHAIN 420 X 66 (INCL #60)
60	2037	MASTERLINK FOR 420 CHAIN
61	13189	REAR WHEEL ASSY 8" (INCLS 62)
62	13500	TIRE - 18/9.5 X 8 BADLAND
63	1430	TUBE - 8 INCH (REPAIR PART ONLY)
64	G0631	LOOM 1.625ID X 6.312L
65	9674-16	SPACER 3/8ID X 3/8L ZINC
66	1847	BOLT 1/4-20 X 1.00 HHCS G5 ZINC
67	8227	NUT 1/4-20 CLIP
68	11387	LOOP CLIP - 1.25 INCH
69	1876	BOLT 1/4-20 X .625 HH WF ZINC
70	13281-2Z	SPINDLE PIVOT W/ZERK - BLACK
71	2449	TINNERMAN NUT
72	12635	TOP COVER
73	12259	BOTTOM COVER
74	11776	TAV COVER
75	9929	VINYL CAP .25 X .25 - BLACK
76	8778	LAP/SHOULDER HARNESS
77	4561	SHOCK ABSORBER
78	9190	BOLT 3/8-16 X 3.25 HHCS G5 ZINC
79	9085	NUT 3/8-16 TOPLOCK HEX ZINC
80	1263	NUT 5/16-18 HEX WF ZINC
81	13315	LEFT TIE ROD END 1/2-20
82	13342	NUT 1/2-20 HEX JAM - LEFT
83	9169	NUT 1/2-20 HEX JAM - RIGHT
84	13314	RIGHT TIE ROD END 1/2-20
85	2388	NUT 3/8-24 HEX ZINC
86	13323-2	STEERING PIVOT - BLACK
87	12634	SEAT
88	13388	BOLT 3/8-16 X 3.75 HHCS G5 ZINC
89	5732	WASHER 1/4 IEL ZINC

PARTS LIST MODELS 616B & 617C

REF	PART #	DESCRIPTION
90	11361	BOLT – FLAG MOUNTING
91	9006	BOLT ¼-20 X .50 HH WF
93	13642	STOP SWITCH WIRE
94	1982-2	PEDAL LATCH – BLACK
95	9158	BOLT 3/8-16 X 2.25 HHCS G5 ZINC
96	5447	SAFETY FLAG – 6 FOOT
97	6320	HEADREST – SINGLE
98	6701	BOLT 5/16-18 X 1.25 SHCS PL
99	6280H	SPROCKET HUB – HEX
100	12638	SIDE PANEL – RIGHT
NI	12637	SIDE PANEL – LEFT
101	6783-16	SPACER 1.00ID X 12G X 4.125 LONG ZINC
102	2265-16	SPACER 1.00ID X 12G X .75 LONG ZINC
103	3941H	BEARING - .875 HEX
104	6617	BEARING FLANGE
105	9338	SPROCKET 420P 60TOOTH
106	12249 12594	ENGINE – 6.5HP OHC (MODEL 616B) ENGINE – 7HP W/COIL (MODEL 617C)
ASM	13100	DRIVER PULLEY (INCLS 107 – 112)
107	**	STATIONARY SHEAVE
108	200349	BRONZE BUSHING
109	**	MOVEABLE SHEAVE
110	**	SHOE ASSEMBLY
111	**	HUB
112	**	DRUM
ASM	13373	DRIVEN PULLEY (INCLS 113 – 119)
113	11342	RETAINING RING
114	**	CAM
115	6805	SPRING
116	6804	NYLON BUTTON
117	**	BUSHING
118	**	STATIONARY SHEAVE
119	**	MOVEABLE SHEAVE
120	9511H	BRAKE DISC – HEX
121	5959	DRIVE BELT
122	9060	WASHER 5/16 TYPE A SAE N ZINC
123	1356	ENGINE STUD
124	1136	NUT 5/8-18 CENTERLOCK HEX JAM ZINC
125	9101	BOLT 5/16-24 X .50 HHCS NYLOCK G5 Z
126	8204	BOLT 5/16-24 X 2.25 HHCS G5 ZINC

REF	PART #	DESCRIPTION
127	1124	WASHER 5/16 SPLITLOCK ZINC
128	1398	WASHER 21/64 ID X 1-1/4 X 1/8
129	8720	SPROCKET 420P 9TOOTH
130	3403	KEY 3/16SQUARE X 2.00
131	1119	SPACER 5/8 ID X 1.062OD X 1/8 THK
132	1938	SPACER 3/4ID X 11G X 3/8 ZINC
133	11808	VINYL CAP 1.50ID X 1.50L – BLACK
134	13598-2	ENGINE BACKING PLATE - BLACK
135	11797H-16	AXLE HEX – ZINC
138	13594-2	CHASSIS WDMT – BLACK
139	13592	SPANNER 5/8ID X 14G X 5.50L
140	2777	JACKSHAFT 5/8 X 10.812L
141	1469	WASHER 5/8ID X 1.062OD X .062 THK
142	1194	WASHER ¼ SAE FLAT ZINC
143	9162	NUT ¾-10 TOPLOCK HEX ZINC
144	5222-16	SPACER 1.00ID X 1.25OD X 1.25L ZINC
145	9810	BRAKE PAD SERVICE KIT (INCLS 146-148)
146	**	ANVIL WITH LINING
147	**	BRAKE LINING
148	3928	BACKING PLATE
149	3930	ACTUATOR PIN
150	3931	ADJUSTER SCREW
151	3932	LOCKNUT
ASM	6534	MB-1 SERVICE KIT (INCLS 152 – 154)
152	**	GROOVE PIN
153	**	LEVER
154	**	BRAKE HOUSING
155	9188	BOLT ½-13 X 1.50 HHCS G5 ZINC
ADDITIONAL PARTS FOR MODEL 617C ONLY		
156	13387-2	LEFT LIGHT MOUNT BRACKET – BLACK
NI	13386-2	RIGHT LIGHT MOUNT BRACKET – BLACK
157	13097	RUNNING LIGHTS – PAIR
NI	13096	35WATT REPLACEMENT BULB
NI	9389	10AMP FUSE

ASM = ASSEMBLY

NI = NOT ILLUSTRATED

** = NOT SOLD SEPERATELY

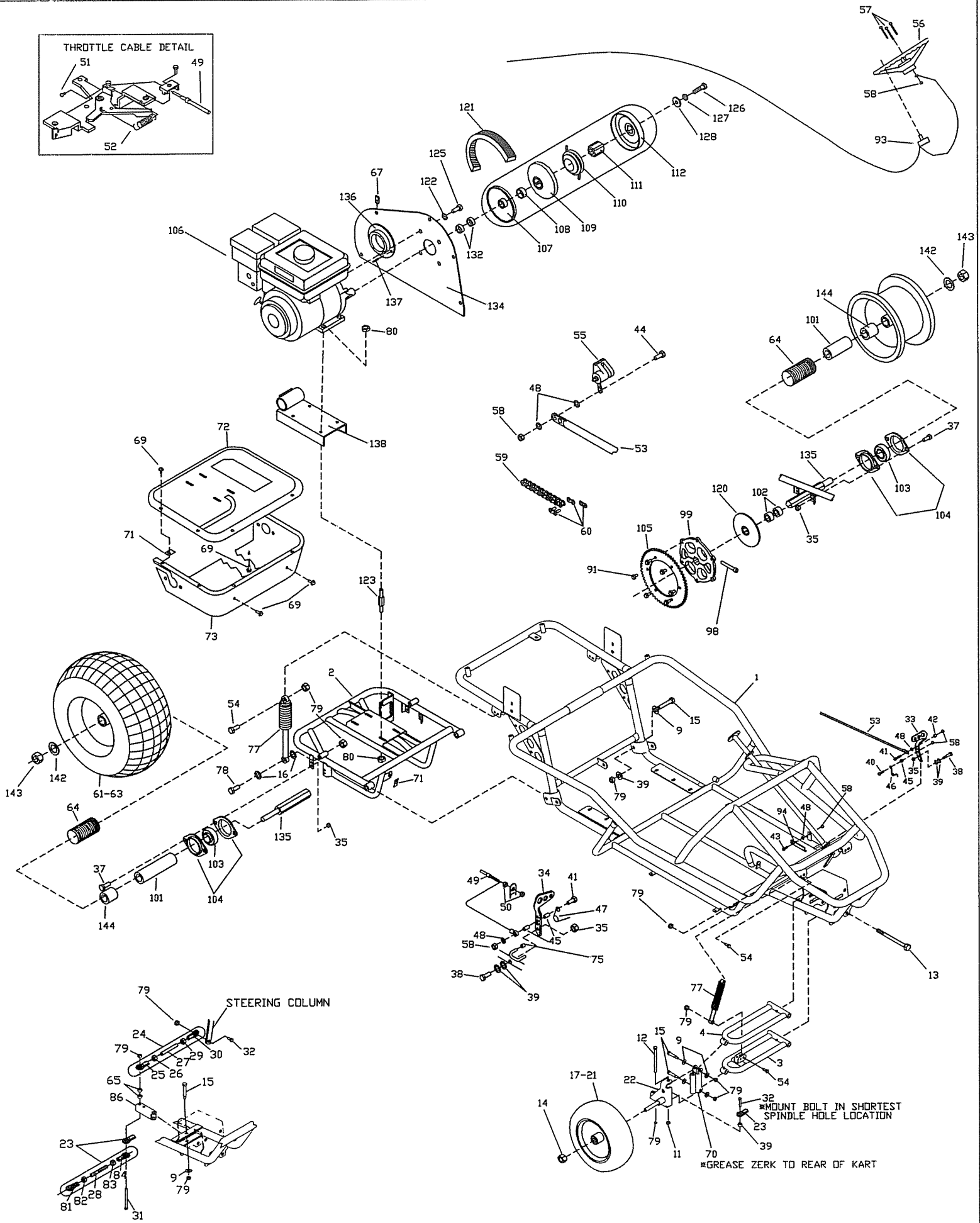
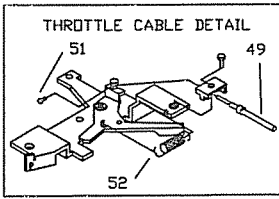

STEERING DETAIL

*MOUNT BOLT IN SHORTEST SPINDLE HOLE LOCATION
 *GREASE ZERK TO REAR OF KART

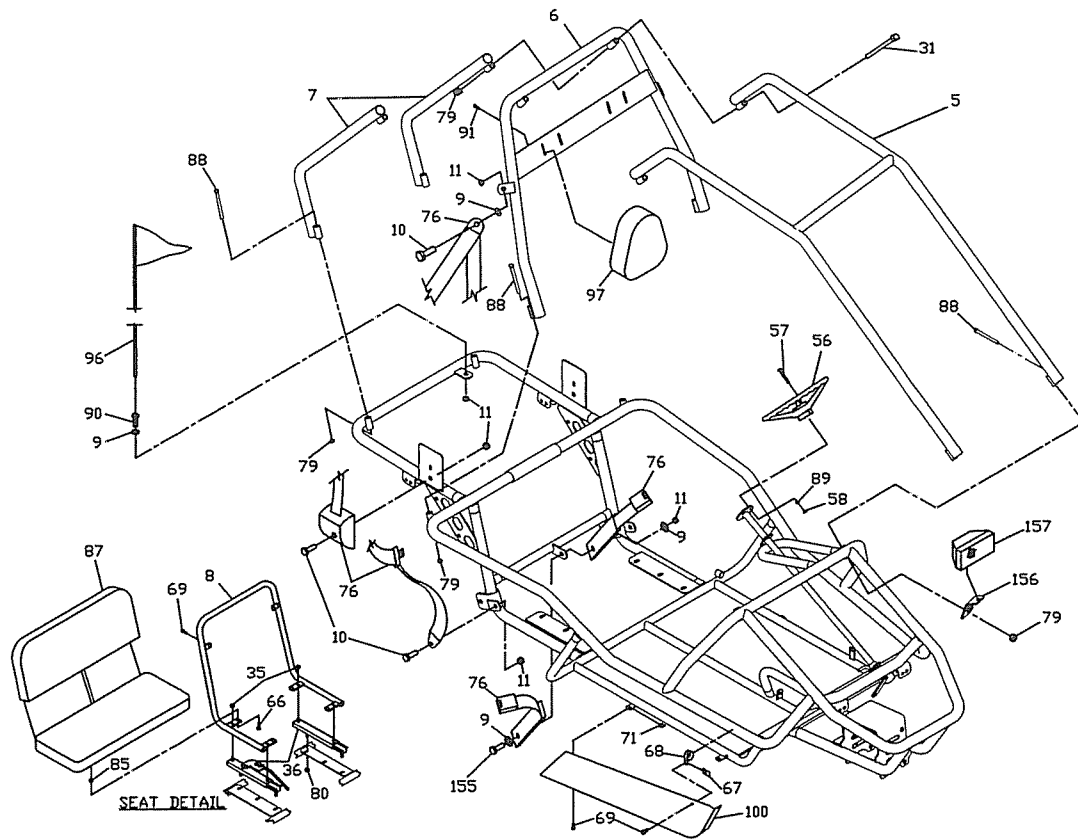

Torque Converter Drive Breakdown

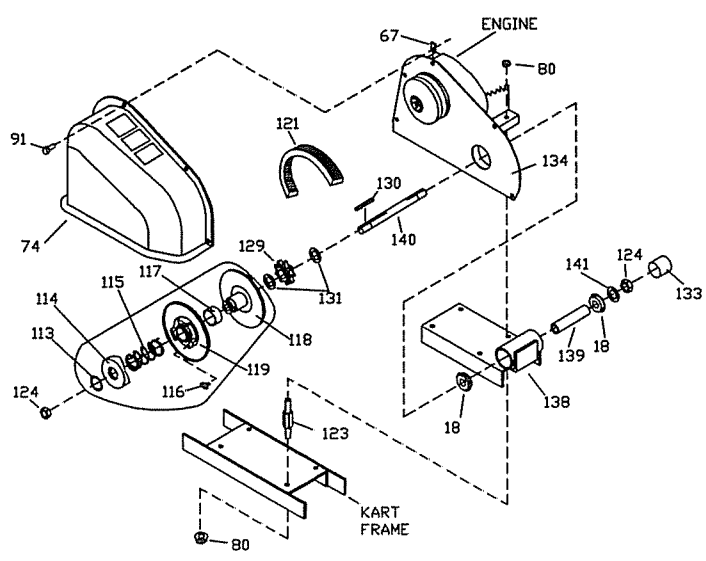

Brake Caliper Breakdown

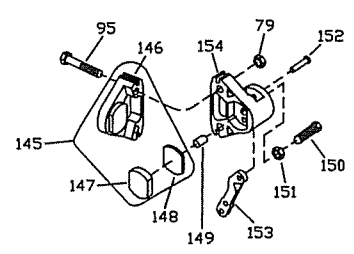

Orientation of lever and hardware may vary.