



## **SERVICE INSTRUCTIONS**

For 6xx Model

### **⚠ WARNING:**

Read Engine Owner's Manual, Vehicle Operator's Manual, and Supplement Carefully Before Operating Vehicle.

Maintenance Instructions



4404 Engle Ridge Drive, Fort Wayne, IN 46804  
ph (260) 432-1596      fx (260) 432-7870

**THIS VEHICLE IS FOR  
OFF-ROAD USE ONLY**

BEFORE OPERATING THIS VEHICLE, THE OWNER AND/OR OPERATOR MUST UNDERSTAND THE VEHICLE WAS NOT DESIGNED OR MANUFACTURED TO MEET SPECIFICATIONS FOR USE ON STREETS, HIGHWAYS, OR THOROUGHFARES AND HAVE READ AND HAVE AN UNDERSTANDING OF ALL THE INSTRUCTIONS FOR SAFE ASSEMBLY AND OPERATION AS WELL AS THE INSTRUCTIONS GOVERNING THE ENGINE AND OTHER PORTIONS OF THE VEHICLE.

# TABLE OF CONTENTS

BRAKE MAINTENANCE PAGE 3-4

STEERING ADJUSTMENT PAGE 5

TORQUE CONVERTER MAINTENANCE PAGE 6

CHAIN TIGHTENING PAGE 7

# BRAKE SYSTEM MAINTENANCE

**⚠ WARNING: DO NOT operate the Fun-Kart if the brake system will not properly stop the Fun-Kart.**

**⚠ WARNING: DO NOT perform maintenance of the brake rotor, pads or caliper until the parts have had sufficient time to cool.**

**⚠ WARNING: DO NOT operate the Fun-Kart without the proper guards in place and fastened.**

## Brake Inspection

Inspect the brake caliper before each use of the Fun-Kart. Always clean and service before each season and when removed from storage. The routine maintenance presented is required to keep the brake system in good working order. Inspect as follows:

- 1) Inspect the entire braking system to ensure all connections are secure and all pivot points move freely
- 2) Check brake pedal travel. Brake linkage should move freely and snap back to rear position when released. Free play should be less than ½" of pedal travel.
- 3) Check that caliper assembly (1) slides freely in the mounting bracket (2) and caliper actuator lever (3) moves freely. Clean and lubricate as required.
- 4) Check brake rotor (4) surface condition. Brake rotor surface should be free of pits, deep grooves, dirt, corrosion, oil and grease. Worn, warped, grooved or pitted rotors must be replaced.

## Brake Adjustment

The brake caliper should be adjusted if brake pedal free play is in excess of ½", brake does not stop the Fun-Kart or the parking brake does not hold the Fun-Kart when applied. If any of these conditions exist on the Fun-Kart, the brake caliper must be serviced immediately. Adjust as follows:

- 1) Make sure the brake pedal (5) and caliper acutator lever (3) are in the rear position.
- 2) Loosen the jam nut (6) and rotate the adjuster screw (7) clockwise until it is snug.
- 3) Back out the adjuster screw counterclockwise ¼ turn.
- 4) While holding the adjuster screw in this position, securely tighten the jam nut.
- 5) Check that the brake pedal arm is against the rear stop (8). If not, the brake rod can be shortened by removing the hex head bolt (9) that holds the brake rod on the brake pedal. Reassemble the bolt in the rear hole (10) of the brake rod and tighten the nut securely.
- 6) Test the brakes for effectiveness and readjust if necessary.

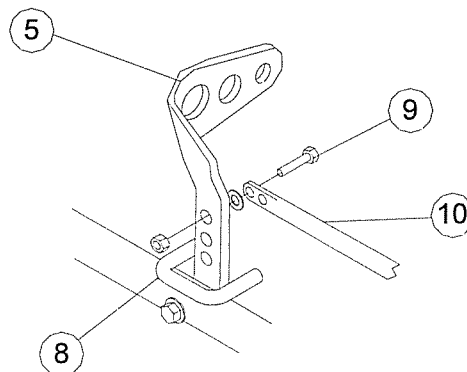
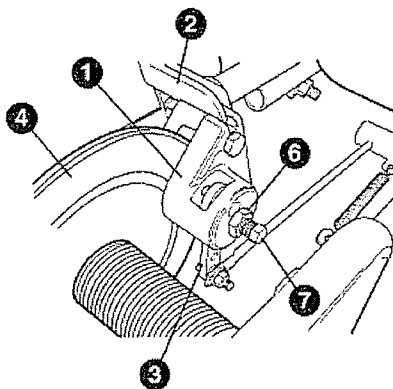

## BRAKE SYSTEM MAINTENANCE – CONT'D

**⚠ WARNING: DO NOT** perform maintenance of the brake rotor, pads or caliper until the parts have had sufficient time to cool.

### Brake Pad Replacement

- 1) Remove left rear wheel and axle spacers.
- 2) Remove brake rod from brake caliper lever.
- 3) Loosen chain (See Chain Tightening Procedure) and remove chain from large drive sprocket.
- 4) Using a rubber mallet, drive the axle towards the passenger side of the Fun-Kart until the caliper is free from the caliper bracket.
- 5) Remove the caliper and loosen jam nut (1) and “back off” adjuster screw (2).
- 6) Remove the two bolts (3) and separate the brake housing (4) and anvil (5).
- 7) Discard the anvil (5).
- 8) Remove the brake housing side brake lining (6), backing plate (7) and actuator pin (8) and inspect the backing plate, acutator pin and brake lever (9) for galling or cracks. Defective parts must be replaced.
- 9) Lubricate the spherical end of the actuator pin, adjusting screw and brake lever ramp areas with high temperature grease and replace the actuator pin into the brake housing spherical end first.
- 10) Place the backing plate into the brake housing then place the new brake lining on top of the backing plate. (Note: Make sure the adjuster screw is completely “backed out” before proceeding)
- 11) Assemble the brake housing and new anvil using the two bolts.
- 12) Replace the caliper on the Fun-Kart frame, and drive the axle back into its original position.
- 13) Connect the brake rod and adjust the caliper per the directions under BRAKE ADJUSTMENT.
- 14) Replace the chain, and tighten (See Chain Tightening Procedure).
- 15) Replace axle spacers and wheel.
- 16) Test the brakes for effectiveness and readjust if necessary.

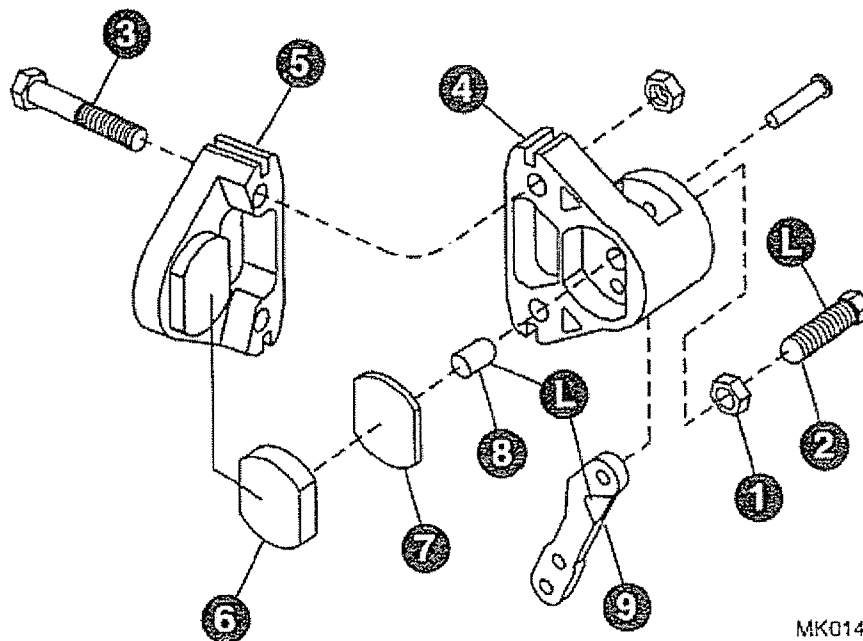

MK014

# STEERING ADJUSTMENT INSTRUCTIONS

**⚠ Warning: Risk of death or Bodily Injury.**

Proper wheel alignment and steering adjustment is critical to the operation and performance of your fun Kart. The following instructions outline the procedure for the adjustment and inspection of the steering and wheel alignment.

The front wheels should be “toed-in” from 1/8” to 1/4”. To check alignment measure distance “A” and “B” (see illustration) to the centerline of the tires with the wheels pointed straight ahead. In a proper “toe-in” condition, dimension “A” should be 1/8” to 1/4” greater than dimension “B”.

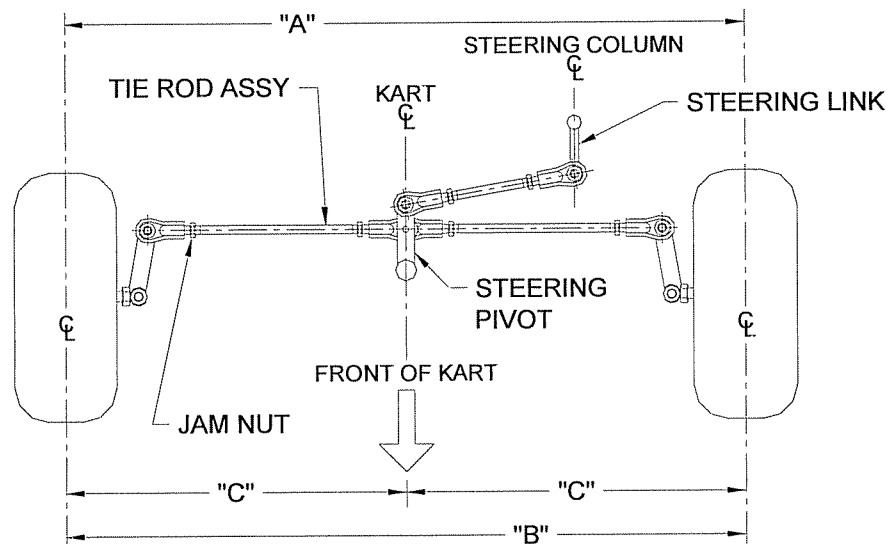

If the wheels require adjustment the following procedure should be followed:

- 1) Loosen and move the jam nuts toward the center of the tie rod assemblies. (Note: The tie rod assembly contains a RH and LH nut)
- 2) Center the steering link at the end of the steering column such that it falls on the same centerline as the kart. (runs parallel to the centerline of the kart as shown)
- 3) Rotate the Rod of the tie rod assembly between the steering link and the steering pivot link until the steering pivot link runs parallel with the centerline of the kart as shown. After adjustment, both the steering link and the steering pivot link should run parallel with each other and with the centerline of the kart as shown.
- 4) Rotate the Rods of the remaining tie rod assemblies to adjust the “toe” of the kart. Shorten the rod assemblies to make distance “B” larger, lengthen the rods to make distance “B” smaller.
- 5) In order to center the wheels, check to see that dimension “C” is equal on both sides of the kart. If not, go back to step (4) and recheck.
- 6) When dimension “A” is 1/8” to 1/4” greater than dimension “B”, and dimension “C” is equal, tighten all jam nuts snugly against the tie rod ends. **TIGHTEN ALL JAM NUTS SECURELY IN PLACE.**
- 7) Recheck all dimensions and repeat the above steps if necessary.

## TORQUE CONVERTER MAINTENANCE

**⚠ WARNING:** Never place any part of your body under the vehicle while it is on a jack or jack stands. If the vehicle is to be started while the tires are off the ground, support the rear of the unit with a pair of suitable jack stands. If these instructions are not followed, vehicle damage, property damage, or personal injury can result.

**⚠ WARNING:** DO NOT operate this vehicle if the torque converter is malfunctioning.

**⚠ WARNING:** DO NOT operate engine without guards in place and fastened.

The torque converter clutch pulley (1), driven pulley (3), and drive belt (2) should be inspected on a regular basis. Check for dirt and frayed belts plus any other potential problems that might be obvious from a visual inspection. If the vehicle is used regularly, the clutch and driven pulleys should be inspected thoroughly each month, or daily if used in very dusty conditions. Always service units before each season. Maximum service interval recommended is every 50 hours of operation. Clutch and driven pulleys must be parallel. Friction surfaces must be smooth and free of dirt, corrosion, oil or grease. Belt must be dry, straight and free of cracks, breaks and uneven wear.

Operating the vehicle in a dusty environment will require more frequent servicing. Indicators of a torque converter system requiring cleaning and lubrication are:

- Erratic or jerky engagement upon acceleration
- Tendency to apparently "lock" into a particular speed
- Excessive drive chain flex

If any of these conditions exist on the kart, the torque converter components and/or the drive chain must be serviced immediately. Both clutch and driven pulleys must be disassembled and cleaned thoroughly of all dust and accumulated dirt. All moving or sliding metal surfaces must be lightly greased (high temperature grease recommended) or lubricated with a graphite type lubricant (such as a spray on type that evaporates leaving the graphite film on the surface) during reassembly. Be careful not to get grease on friction surfaces or the torque converter belt. All guards should be replaced. After assembly, the rear of the frame must be blocked up with suitable jack stands so that the rear tires are not in contact with the ground. The engine should be started and run through its entire operating range to ensure proper operation of the torque converter assembly.

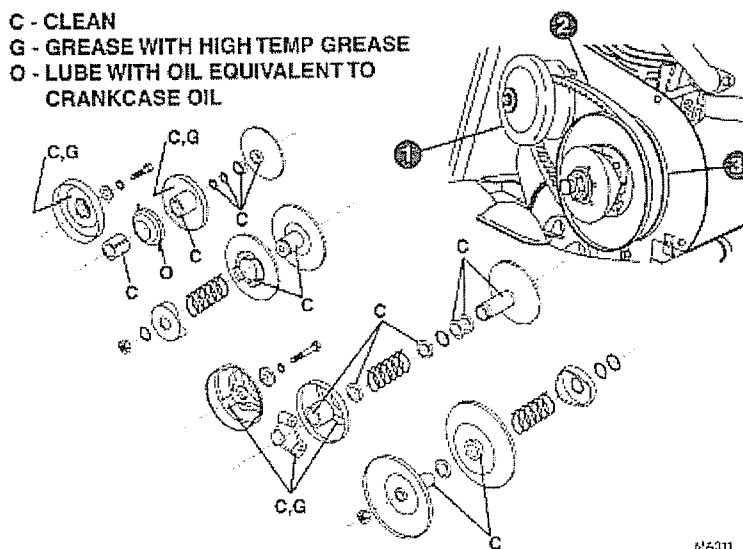

## CHAIN TIGHTENING PROCEDURE FOR THE 6XX

- 1) Loosen the 4 nuts under the engine base that hold the engine in place.
- 2) Remove the 5 bolts holding the torque converter cover on.
- 3) Pull the black TAV chassis towards the rear of the kart until the chain has approximately 1/4" to 3/8" chain flex in both directions.
- 4) Tighten the 4 nuts under the engine base and recheck the chain tension.
- 5) Repeat the above steps if necessary.
- 6) Replace the torque converter guard.

 **WARNING: IF THE GUARDS ARE NOT IN PLACE THERE IS A RISK OF SEVERE HARM TO OPERATOR OR PASSENGER**

