

OPERATOR'S MANUAL

SUPPLEMENT

Model No. 606C-14

⚠ WARNING:

Read Engine Owner's Manual, Vehicle Operator's Manual, and Supplement Carefully Before Operating Vehicle.

Parts List



4404 Engle Ridge Drive, Fort Wayne, IN 46804
ph (260) 432-1596 fx (260) 432-7870

**THIS VEHICLE IS FOR
OFF-ROAD USE ONLY**

BEFORE OPERATING THIS VEHICLE, THE OWNER AND/OR OPERATOR MUST UNDERSTAND THE VEHICLE WAS NOT DESIGNED OR MANUFACTURED TO MEET SPECIFICATIONS FOR USE ON STREETS, HIGHWAYS, OR THOROUGHFARES AND HAVE READ AND HAVE AN UNDERSTANDING OF ALL THE INSTRUCTIONS FOR SAFE ASSEMBLY AND OPERATION AS WELL AS THE INSTRUCTIONS GOVERNING THE ENGINE AND OTHER PORTIONS OF THE VEHICLE.

PARTS LIST MODEL 606C-14

REF	PART#	DESCRIPTION
1	12617-39	FRAME – TRAFFIC YELLOW
2	12628-2Z	REAR SWING ARM WITH ZERK
3	12564-2Z	FRONT SWING ARM WITH ZERK
4	12623-2	OVERHEAD BAR – BLACK
5	12554-2	CENTER/REAR BAR – BLACK
6	12550-2	SEAT FRAME – BLACK
7	9022	WASHER ½ STD FLAT ZINC
8	9188	BOLT ½-13 X 1.50 HHCS G5 ZINC
9	1012	NUT ½-13 TOPLOCK HEX ZINC
10	1264	BOLT ½-13 X 3.75 HHCS G2 ZINC
11	10834	BOLT ½-13 X 7.00 HHCS G5 ZINC
12	1104	SPLIT SPACER .812OD X .625ID X 1.00
13	12611-2	STEERING PIVOT – BLACK
14	13354	NUT 5/8-11 CENTERLOCK HEX ZINC
15	12141	SHOULDER BOLT – ½ X 1.875
16	9125	WASHER 3/8 FLAT USS ZINC
17	13398	WHEEL ASSY 15/6 X 6 (INCL 18 – 20)
18	5090	BEARING 5/8ID X 1-3/8 OD SNAP RING
19	**	SPANNER
20	13465	TIRE – 15/6 X 6 TURF MASTER
22	12497-2Z	SPINDLE WITH ZERK - BLACK
23	5431	TIE ROD ASSY 13.25IN. (INCL 25,26,28-30)
ASM	12655	TIE ROD ASSY 4IN. (INCL 25-27,29,30)
25	1414	TIE ROD END – RIGHT
26	9092	NUT 3/8-24 HEX JAM – RIGHT
27	12654	TIE ROD – 4 INCH
28	5430	TIE ROD – 13.25 INCH
29	9024	NUT 3/8-24 JAM – LEFT
30	1415	TIE ROD END – LEFT
31	6452	BOLT 3/8-16 X 5.00 HHCS G5 ZINC
32	9146	BOLT 3/8-16 X 1.50 HHCS G5 ZINC
33	6293-16	BRAKE PEDAL
34	6309-16	THROTTLE PEDAL
35	1189	NUT 5/16-18 TOPLOCK HEX ZINC
36	6734	SEAT SLIDE – PAIR
37	9176	BOLT 5/16-18 X 1.00 HHCS G5 ZINC
38	1447	SHOULDER BOLT 5/16-18 X 11/16 THD
39	9091	WASHER 3/8 FLAT SAE ZINC
40	9160	BOLT ¼-20 X .875 HHCS NL G5 ZINC
41	1848	BOLT ¼-20 X 1.25 HHCS G5 ZINC
42	6349	BUSHING 5/16OD X 22G
43	1846	BOLT ¼-20 X .750 HHCS G5 ZINC
44	1847	BOLT ¼-20 X 1.00 HHCS G5 ZINC
45	1389	BUSHING .25ID X .313
46	9502	PEDAL SPRING – LEFT WOUND
47	9503	PEDAL SPRING – RIGHT WOUND
48	1854	WASHER NBR 14 FLAT ZINC
49	8251	THROTTLE CABLE (INCLUDES 50)
50	9058	NUT 5/16-24 HEX JAM ZINC
51	12347	SWIVEL SCREW
52	12348	RETURN SPRING

REF	PART#	DESCRIPTION
53	12636-2	BRAKE ROD – BLACK
54	9145	BOLT 3/8-16 X 1.75 HHCS G5 ZINC
55	9597	BRAKE CALIPER
56	12496	STEERING WHEEL
NI	12481	DECORATIVE CAP FOR STEERING WHEEL
57	9103	BOLT ¼-20 X 2.00 HHCS G2 ZINC
58	9057	NUT ¼-20 TOPLOCK ZINC
59	6511	CHAIN 420 X 66 (INCL 60)
60	2037	MASTER LINK FOR 420 CHAIN
61	13399	WHEEL ASSY 18/850 X 8 (INCL 62)
62	13466	TIRE – 18/850 X 8 TURF MASTER
64	G0631	LOOM 1.625ID X 6.312
65	9674-16	SPACER 3/8ID X 3/8 ZINC
66	1847	BOLT ¼-20 X 1.00 HHCS G5 ZINC
67	8227	NUT ¼-20 CLIP
68	8266	LOOP CLIP – 1 INCH
69	1876	BOLT ¼-20 X .625 HH WF ZINC
71	2449	TINNERMAN NUT
72	12635	TOP COVER
73	12259	BOTTOM COVER
74	11776	TAV COVER
75	9929	BLACK VINYL CAP – ¼ INCH
76	8778	SEAT BELT - LAP/SHOULDER HARNESS
77	4561	SHOCK ABSORBER
78	9190	BOLT 3/8-16 X 3.25 HHCS G5 ZINC
79	9085	NUT 3/8-16 TOPLOCK HEX ZINC
80	1263	NUT 5/16-18 HEX WF ZINC
85	2388	NUT 3/8-24 HEX ZINC
86	12762	SHOULDER BOLT ½ X 1-1/2
87	12634	SEAT
91	9006	BOLT ¼-20 X .50 HH WF ZINC
92	12323	STOP SWITCH WIRE ASSEMBLY
93	12459	TALL TOGGLE SWITCH ASSEMBLY
94	1982-2	PEDAL LATCH -- BLACK
100	12638	SIDE PANEL – RIGHT
NI	12637	SIDE PANEL – LEFT
NI	12860	RUN LIGHT KIT
NI	13097	REPLACEMENT LIGHTS - PAIR
NI	13096	35WATT REPLACEMENT BULB
NI	9389	10 AMP GLASS FUSE (FOR RUN LIGHTS)
105	12250	6.5HP ENGINE WITH COIL
ASM	13100	DRIVER PULLEY (INCL 107 – 112)
107	**	STATIONARY SHEAVE
108	200349	BRONZE BUSHING
109	**	MOVEABLE SHEAVE
110	**	SHOE ASSEMBLY
111	**	HUB
112	**	DRUM
ASM	13373	DRIVEN PULLEY (INCL 114 – 120)
114	11342	RETAINING RING

PARTS LIST MODEL 606C-14

REF	PART #	DESCRIPTION
115	**	CAM
116	6805	SPRING
117	6804	NYLON BUTTON
118	**	BUSHING
119	**	STATIONARY SHEAVE
120	**	MOVEABLE SHEAVE
121	5959	BELT
122	9060	WASHER 5/16 TYPE A SAE ZINC
123	1356	ENGINE STUD ASSEMBLY
124	1136	NUT 5/8-18 CENTERLOCK HEX JAM ZINC
125	9101	BOLT 5/16-24 X .50 HHCS G5 NL ZINC
126	8204	BOLT 5/16-24 X 2.25 HHCS G5 ZINC
127	1124	WASHER 5/16 SPLIT LOCK ZINC
128	1398	WASHER 21/64ID X 1-1/4OD X 1/8 THK
129	8720	SPROCKET 420P 9TOOTH
130	3403	KEY 3/16 SQ X 2.00
131	1119	SPACER .625ID X 1.062OD .125THK
132	1938	SPACER .75ID X 11G X .375
133	11808	VINYL CAP 1.5ID X 1.5 LONG – BLACK
134	13598-2	ENGINE BACKING PLATE - BLACK
138	13594-2	CHASSIS WLDMNT – BLACK
139	13592	SPANNER 5/8ID X 14G X 5.50
140	2777	JACKSHAFT 5/8 X 10.812
141	1469	WASHER .625ID X 1.062OD X .062 THK
142	11797H-16	AXLE WLDMNT HEX – YELLOW ZINC
143	9511H	BRAKE DISC HEX
144	5222-16	SPACER 1.00ID X 1.25OD X 1.25L ZINC
145	6783-16	SPACER 1.00ID X 12G X 4.125L ZINC
146	2265-16	SPACER 1.00ID X 12G X .75L ZINC
147	3941H	SEAL BEARING 7/8 HEX
148	6617	BEARING FLANGE – HEAVY
149	1194	WASHER 3/4 SAE FLAT ZINC
150	9162	NUT 3/4-10 TOPLOCK HEX ZINC
151	9338	SPROCKET 420P 60TOOTH
152	6280H	SPROCKET HUB – HEX
153	6701	BOLT 5/16-18 X 1.25 SHCS
155	6320	HEADREST – SINGLE
156	5447	SAFETY FLAG – 6 FOOT
158	9810	BRAKE PAD KIT (INCL 159 – 161)
159	**	ANVIL WITH LINING
160	**	BRAKE LINING
161	3928	BACKING PLATE
162	3930	ACTUATOR PIN
163	3931	ADJUSTER SCREW
164	3932	LOCKNUT
165	9158	BOLT 3/8-16 X 2.25 HHCS G5 ZINC
ASM	6534	SERVICE KIT (INCL 166 – 168)
166	**	GROOVE PIN
167	**	LEVER
168	**	BRAKE HOUSING

REF	PART #	DESCRIPTION
169	11361	FLAG MOUNTING BOLT
171	2386	BOLT 3/8-16 X 3.50 HHCS G5 ZINC

ASM = ASSEMBLY

NI = NOT ILLUSTRATED

****** = NOT SOLD SEPERATELY

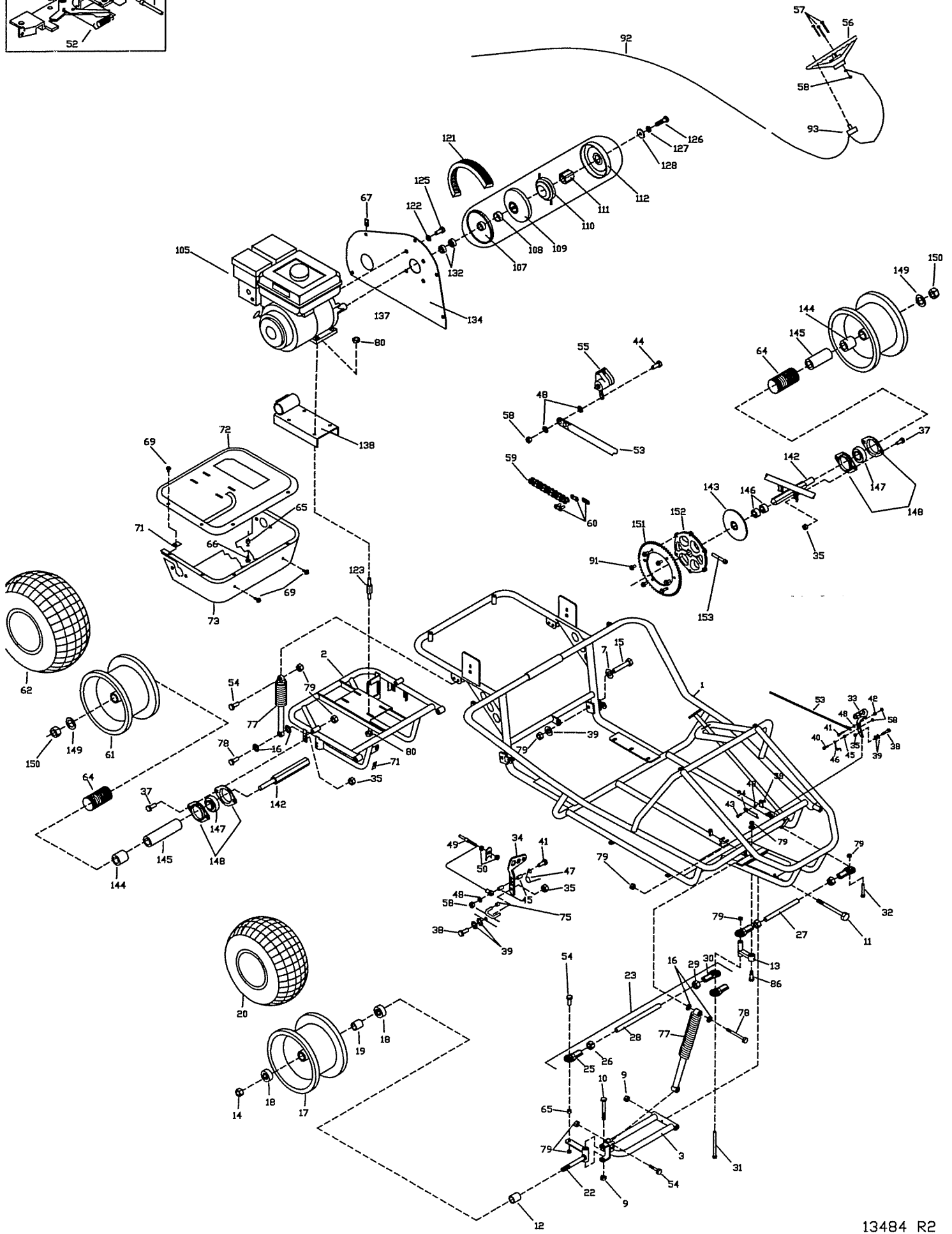
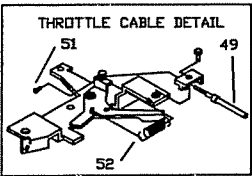

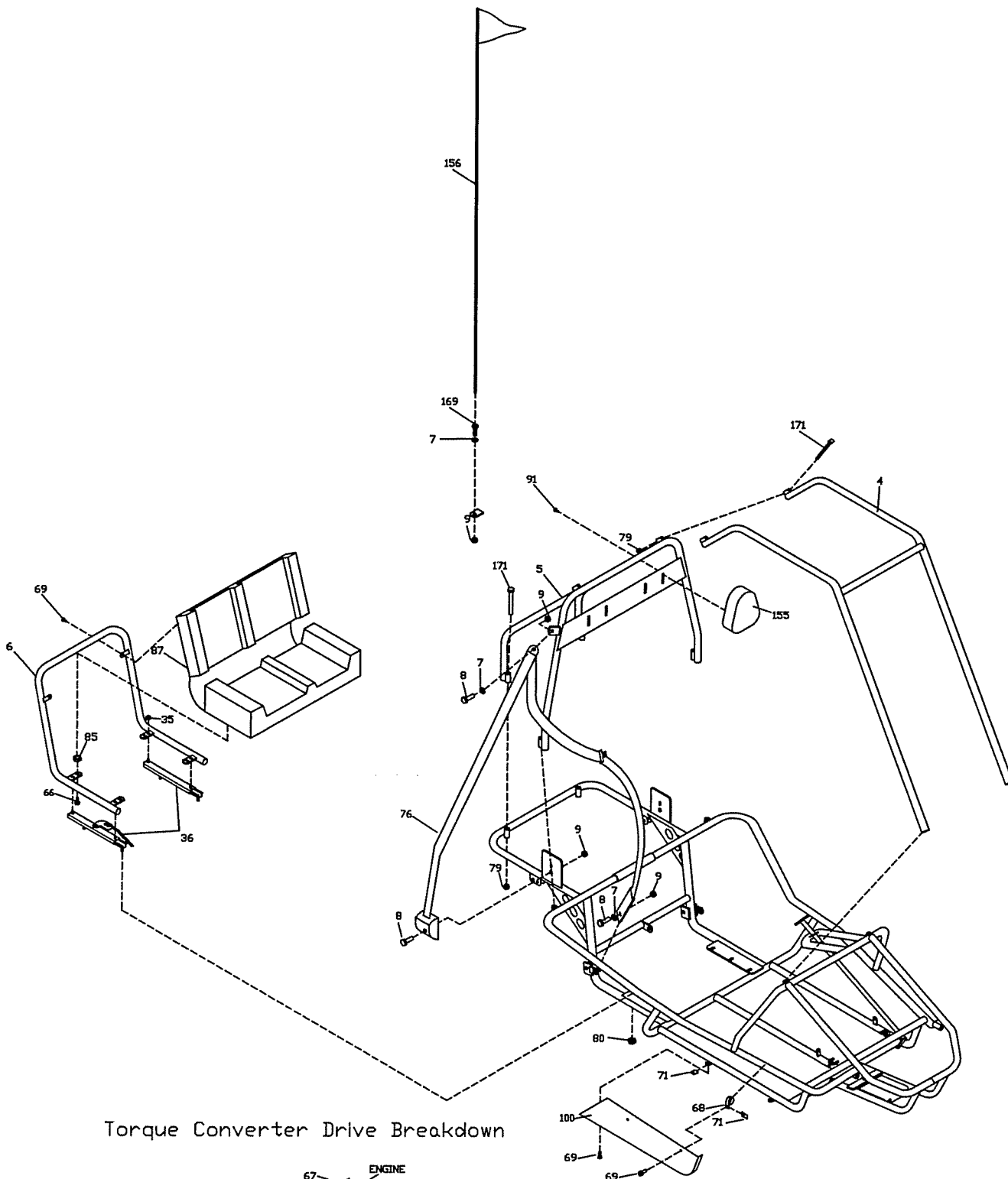

Torque Converter Drive Breakdown

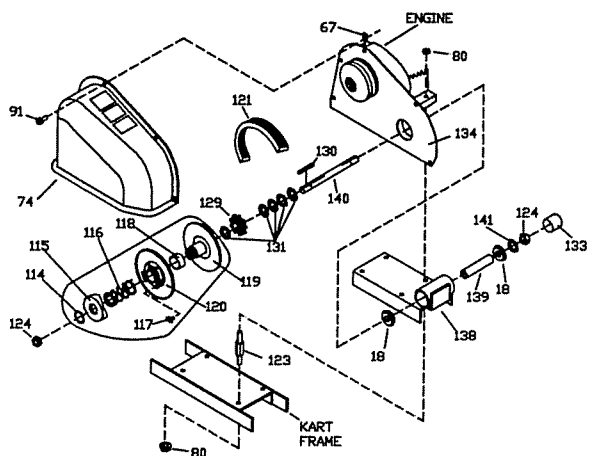

Brake Callper Breakdown

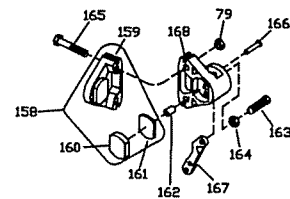

Orientation of lever and hardware may vary.