

# Operator's Manual SUPPLEMENT

MANCO MODEL NO.

485-152

485-162

485-191

**WARNING:**  
Read Engine  
Owner's Manual,  
Vehicle Operator's  
Manual, and  
Supplement  
Carefully Before  
Operating  
Vehicle.

Parts List



(Unit Pictured is 485-152)

***MANCO***  
***PRODUCTS, INC.***

4404 Engle Ridge Drive Ft. Wayne, Indiana 46804 219-432-1596

**THIS VEHICLE IS FOR  
OFF-ROAD USE ONLY**

BEFORE OPERATING THIS VEHICLE, THE OWNER AND/OR OPERATOR MUST UNDERSTAND THE VEHICLE WAS NOT DESIGNED OR MANUFACTURED TO MEET SPECIFICATIONS FOR USE ON PUBLIC ROADS, STREETS, HIGHWAYS, OR THOROUGHFARES AND HAVE READ AND HAVE AN UNDERSTANDING OF ALL THE INSTRUCTIONS FOR SAFE ASSEMBLY AND OPERATION AS WELL AS THE INSTRUCTIONS GOVERNING THE ENGINE AND OTHER PORTIONS OF THE VEHICLE.

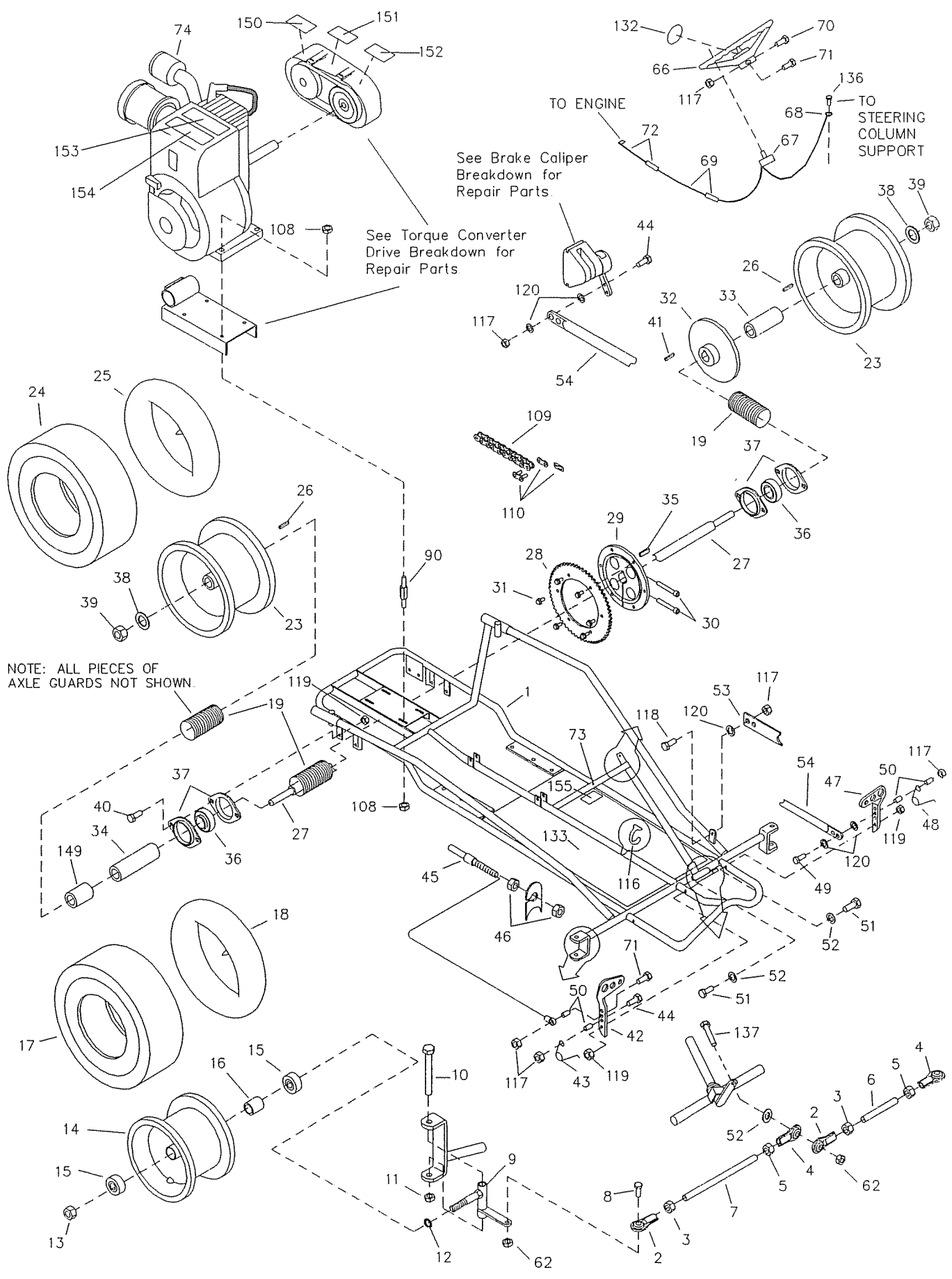

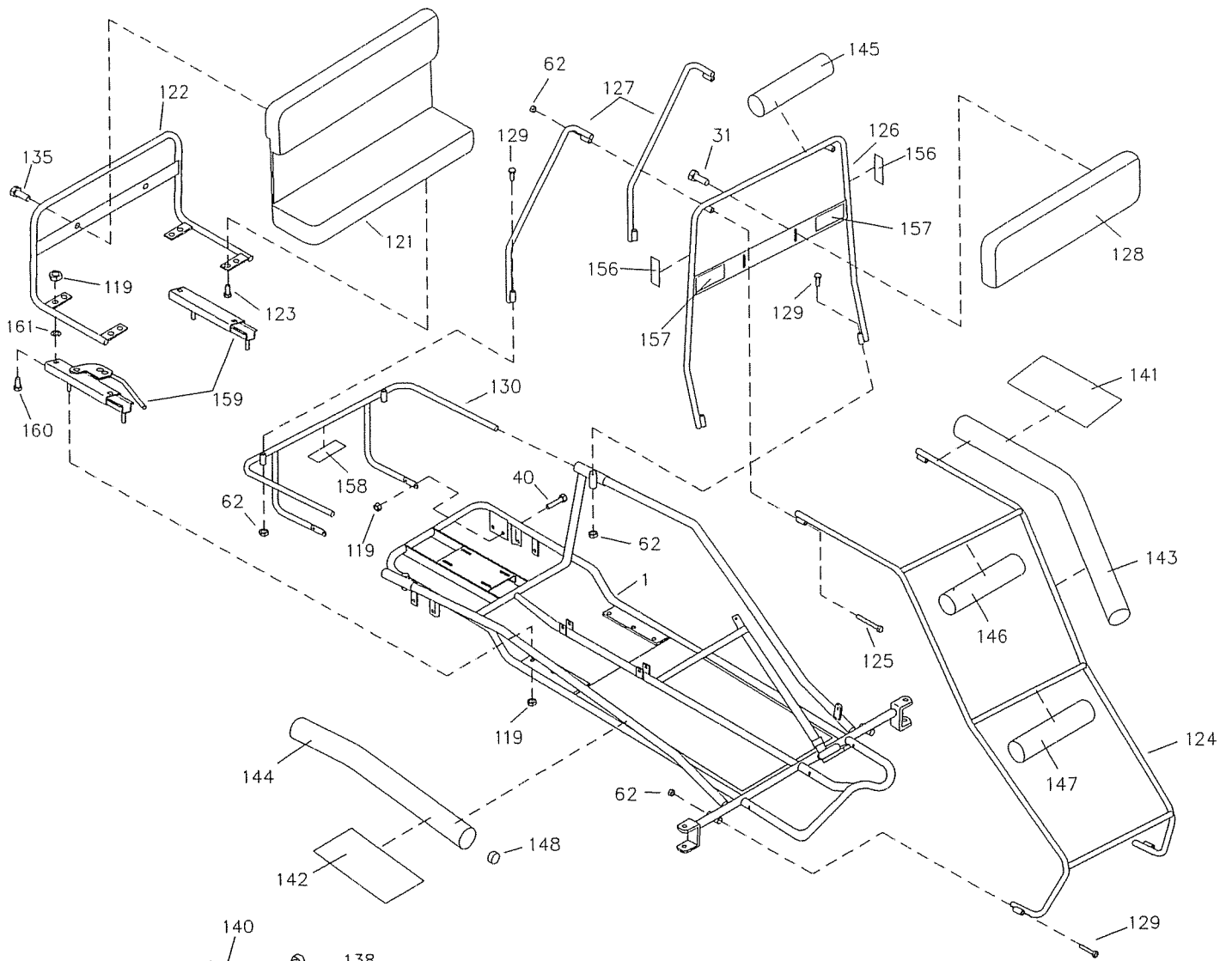

### Torque Converter Drive Breakdown

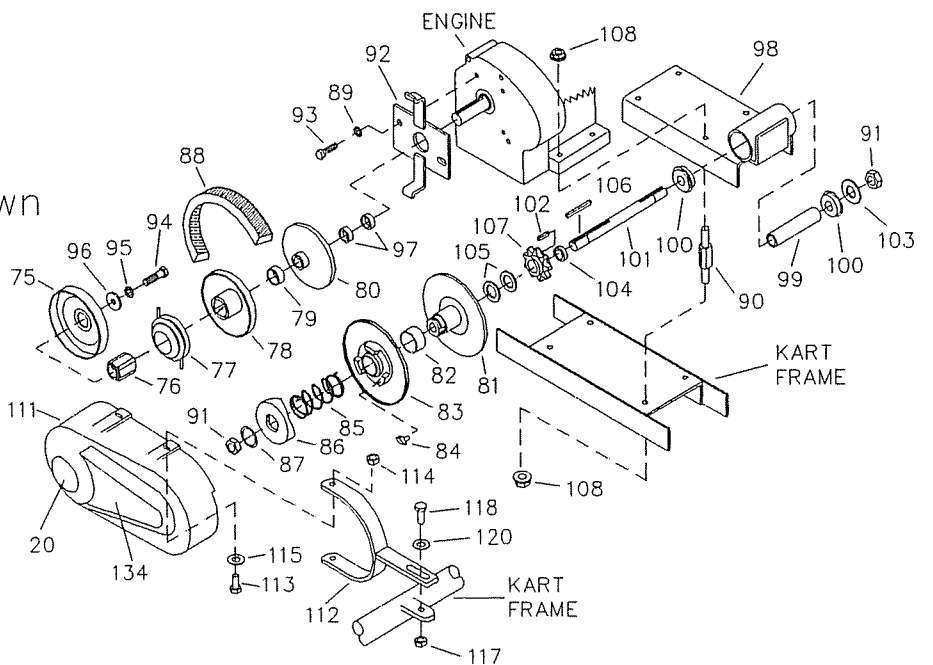

### Brake Caliper Breakdown

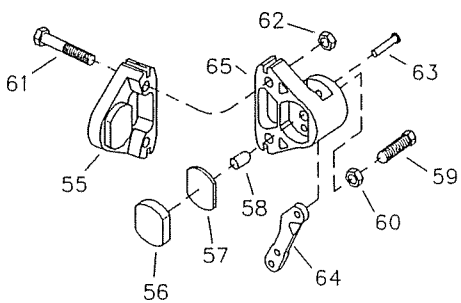

REPAIR PARTS - MODEL 485-152/-162/-191

REF NO.	PART NO.	DESCRIPTION	REF NO.	PART NO.	DESCRIPTION
1	8175-2	Frame	49	1849	Bolt, 1/4-20 x 1-1/2"
ASM	4358	Tie Rod Asm. Short (incl. 2-6)	50	1389	Bushing, 1/4ID x 5/16"
ASM	9322	Tie Rod Asm. Long (incl 2-5,7)	51	9110	Bolt, 5/16-18 x 1-1/2"
2	1414	Tie Rod End, RH Thread	52	9091	Washer, 3/8" Flat
3	9092	Nut, 3/8-24 Jam RH	53	1982	Pedal Latch
4	1415	Tie Rod End, LH Thread	54	9599-2	Brake Rod
5	9024	Nut, 3/8-24 Jam LH	ASM	9598	Brake Caliper (incl. 55-65)
6	4356	Tie Rod, Short	ASM	9810	Brake Pad Service Kit (incl. 55-57)
7	9321	Tie Rod, Long	55	*	Anvil w/Lining
8	9146	Bolt, 3/8-16 x 1-1/2"	56	*	Brake Lining
NI	6256-2	Spindle, LH	57	3928	Backing Plate
9	6257-2	Spindle, RH	58	3930	Actuator Pin
10	1264	Bolt, 1/2-13 x 3-1/2"	59	3931	Adjuster Pin
11	1012	Nut, 1/2-13 Toplock	60	3932	Nut, Jam
12	5157	Spacer, 5/8ID x 3/4"	61	9158	Bolt, 3/8-16 x 2-1/4"
13	1046	Nut, 5/8-11 Toplock	62	9085	Nut, 3/8-16 Toplock
14	9309FP	Wheel Asm, Front (incl. 15-18)	ASM	6534	MB-1 Service Kit (incl. 63-65)
15	5090	Bearing, 5/8" ID	63	*	Groove Pin
16	5950	Spanner, 5/8ID x 2-1/8"	64	*	Lever
17	4915	Tire, 145/70 x 6 Knobby	65	*	Brake Housing
18	3802	Tube, 6"	66	6038	Steering Wheel
19	K485-13	Axle Guard Repair Kit	ASM	9799	Stop Switch Asm (incl. 67-69)
20	8171	Decal, Round Black Fox, 485-191 Only	67	1392	Switch, Toggle
21	-----	-----	68	1393	Ring Terminal
22	-----	-----	69	1394	Wire, 50" w/ Splice Connector
ASM	6289P	Wheel Asm, Rear (incl. 23-24)	70	9080	Bolt, 1/4-20 x 2-3/4"
23	9606	Rim, 7" Black	71	9160	Bolt, 1/4-20 x 7/8"
24	9607	Tire, 16 x 8 - 7"	72	1406	Wiring Harness
25	9609	Tube, 16 x 8 - 7" (Repair Part Only)	73	1463	Bushing, Insulating
26	6123	Key, 1/4 sq. x 1-3/4"	74	9890	Engine, 5hp, 485-152/-162
27	9323	Axle Shaft		1763	Engine, 5hp, 485-191
ASM	9570	Sprocket Asm (incl. 28-31)	ASM	5957	Pulley, Driver (incl. 75-80)
28	9338	Sprocket, 420P 60T	75	*	Drum
29	6280	Sprocket Hub	76	*	Hub
30	6701	Bolt, 5/16-18 x 1"	77	*	Shoe Assembly
31	1876	Bolt, 1/4-20 x 5/8"	78	*	Moveable Sheave
32	9511	Brake Disc, 6"	79	200349	Bushing
33	4913	Spacer, 1"ID x 3"	80	*	Stationary Sheave
34	1448	Spacer, 1"ID x 3-9/16"	ASM	5958	Pulley, Driven (incl. 81-87)
35	9680	Key, 1/4 x 3/8 x 1-1/4"	81	*	Stationary Sheave
36	3941	Bearing	82	*	Bushing
37	1760	Bearing Flange	83	*	Moveable Sheave
38	1194	Washer, 3/4" Flat	84	6804	Button, Nylon
39	9162	Nut, 3/4-10 Toplock	85	6805	Spring
40	2264	Bolt, 5/16-18 x 3/4"	86	*	Cam
41	1775	Key, 1/4sq. x 1-1/4"	87	2477	Retaining Ring
42	1437	Pedal, Throttle	88	5959	Belt
43	9502	Spring, Left Wound	89	9030	Washer, 5/16 Interlock
44	1847	Bolt, 1/4-20 x 1"	90	1356	Stud
45	1496	Cable, Throttle (incl. 46)	91	1136	Nut, 5/8-16 Toplock
46	9058	Nut, 5/16-24 Jam	92	1494	Mounting Bracket
47	1436	Pedal, Brake	93	9101	Bolt, 5/16-24 x 1/2" Nylock
48	9503	Spring, Right Wound	94	1454	Bolt, 5/16-24 x 1-3/4"

## REPAIR PARTS - MODEL 485-152/-162/-191

REF NO.	PART NO.	DESCRIPTION	REF NO.	PART NO.	DESCRIPTION
95	1124	Washer, 5/16" Split Lock	134	6593	Decal, Drive Cover, 485-152
96	1398	Washer, 21/64" ID x 1-1/4"		9499	Decal, Drive Cover, 485-162
97	1938	Spacer, 3/4ID x 3/8" (Qty=1, -191 Only)		8172	Decal, Drive Cover, 485-191
	1442	Spacer, 3/4ID x 1/4" (Qty=2, -XX2 Only)	135	9006	Bolt, 1/4-20 x 1/2" Whiz Flange
98	1110	Chassis, Torque Converter	136	9796	Screw, Self-Tapping
99	1116	Spanner, 5/8ID x 4-13/16"	137	9145	Bolt, 3/8-16 x 1-3/4"
100	5090	Bearing, 5/8ID	138	9118	Clevis Pin
101	1118	Jackshaft	139	9116	Cotter Pin
102	1031	Key, 3/16 sq. x 1/2"	140	4372	Handhold Strap
103	1469	Washer, 5/8ID x 1"OD	141	9779	Top Pad Cover, 485-152 Only
104	1937	Spacer, 5/8ID x 1/4"	142	9778	Arm Pad Cover, 485-152
105	1119	Spacer, 5/8ID x 1/8" (Qty=2, -191 Only)		9797	Arm Pad Cover, 485-162
	1119	Spacer, 5/8ID x 1/8" (Qty=1, -XX2 Only)	ASM	9798**	Foam Replacement Kit (incl. 143-147)
106	3403	Key, 3/16 sq. x 2"	143	9758**	Foam, 43"
107	1125s	Sprocket, #420 9T	144	9759**	Foam, 30"
108	1263	Nut, 5/16-18 Whiz Flange	145	9760**	Foam, 22"
109	9515	Chain, #420 x 64P (incl. 110)	146	9761**	Foam, 21"
110	2037	Masterlink, #420	147	9762**	Foam, 20"
111	1542	Cover, Torque Converter	148	9776	Clamp, Foam Stop 3/4"
112	1537-2	Rear Mounting Bracket	149	2265	Spacer, 1"ID x 3/4"
113	2277	Bolt, 8-32 x 1/2"	150	1049	Decal, Caution
114	2278	Nut, 8-32 Toplock	151	4912	Decal, Chainguard Warning
115	2279	Washer, #8 Flat	152	9610	Decal, Tire Pressure
116	1019	Ty-Wrap	153	9677	Decal, Warning: Hot Surfaces
117	9057	Nut, 1/4-20 Toplock	154	9678	Decal, Warning: Engine Exhaust
118	1846	Bolt, 1/4-20 x 3/4"	155	8154	Decal, Age Restriction
119	1189	Nut, 5/16-18 Toplock	156	6540	Decal, Warning: Wear Helmet
120	1854	Washer, #14 Flat	157	8138	Decal, Warning: Entanglement
121	8134	Seat Back/Bottom	158	9679	Decal, Warning: No Riders Allowed
122	9968-2	Seat Frame	159	6734	Seat Slide Pair
123	9189	Bolt, 1/4-20 x 7/8"	160	9990	Carriage Bolt, 5/16-18 x .625, Rd. Head
124	9539-2	Front Bar	161	9989	Washer, Retaining
125	6452	Bolt, 3/8-16 x 5"	NI	5964	Decal, Oil Warning
126	9546-2	Center Bar	NI	2684B	Eng. Operator's Manual, 485-191
127	9549-2	Rear Upright	NI	2684C	Eng. Operator's Manual, 485-152/-162
128	6580	Headrest Pad, 485-152	NI	4350	Operator's Manual
	9500	Headrest Pad, 485-162	NI	9212R3	Assembly Instructions
	6217	Headrest Pad, 485-191			
129	2386	Bolt, 3/8-16 x 3-1/2"			
130	9553-2	Rear Bar			
131	9680	Key, 1/4 x 3/8 x 1-1/4"			
132	6592	Decal, Steering Wheel, 485-152			
	9498	Decal, Steering Wheel, 485-162			
	8171	Decal, Round Black Fox, 485-191			
133	6595	Decal, Floor Pan Set, 485-152			
	9497	Decal, Floor Pan Set, 485-162			
	8174	Decal, Floor Pan Set, 485-191			

ASM = Assembly

NI = Not Illustrated

\* = Not Sold Separately

\*\* = Specify Black, Pink, White, Yellow

# THROTTLE CABLE INSTALLATION

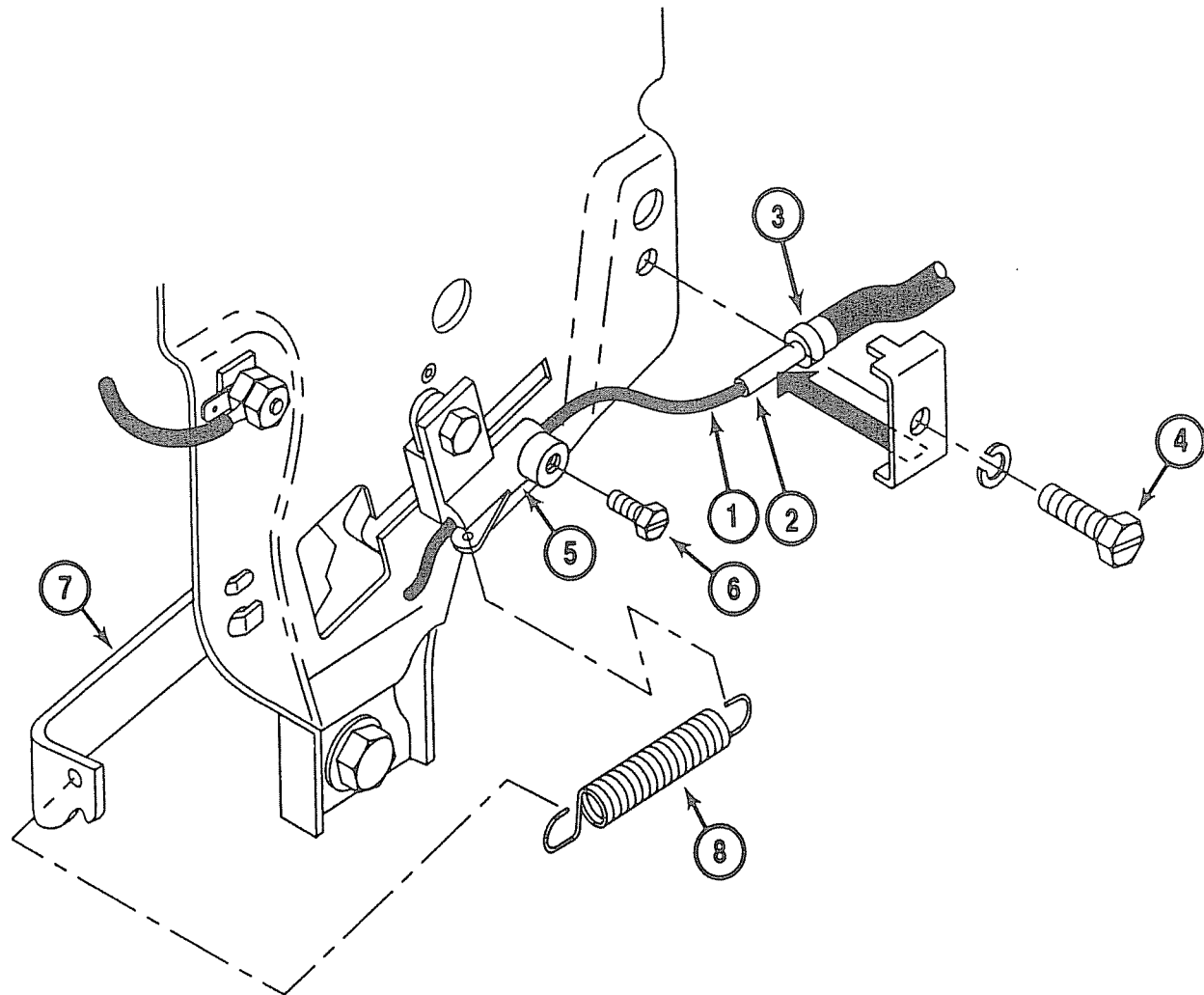

**ASSEMBLY:** Pass the Throttle Cable (Item 1) through the 1628 Cable Retainer (Item 2) and butt the Throttle Cable Housing End (Item 3) against the Inside Shoulder of the 1628 Cable Retainer (Item 2). The 1628 Cable Retainer (Item 2) is to be securely fastened to the engine with the Clamping Screw (Item 4). Pass the Wire End of the Throttle Cable Housing (Item 1) through the hole in the 5928 Cable Stop (Item 5). Before tightening 5929 Cable Stop Screw (Item 6):

1. Ensure 5926 Spring Anchor (Item 7), 5927 Spring (Item 8) and Throttle Cable are installed as illustrated above.
2. Ensure throttle pedal is in rearward (idle) position.
3. Ensure that there is no slack in the Throttle Cable Wire End (Item 1) with no tension applied to the spring (Item 8).
4. Ensure Throttle Cable Housing End (Item 3) is inside and against the 1628 Cable Retainer (Item 2).