

Operator's Manual SUPPLEMENT

MANCO MODEL NO.

405-20

405-26

WARNING:
Read Engine
Owner's Manual,
Vehicle Operator's
Manual, and
Supplement
Carefully Before
Operating
Vehicle.

Parts List



(UNIT PICTURED IS MODEL 405-20)

MANCO
PRODUCTS, INC.

4404 Engle Ridge Drive Ft. Wayne, Indiana 46804 219-432-1596

**THIS VEHICLE IS FOR
OFF-ROAD USE ONLY**

BEFORE OPERATING THIS VEHICLE, THE OWNER AND/OR OPERATOR MUST UNDERSTAND THE VEHICLE WAS NOT DESIGNED OR MANUFACTURED TO MEET SPECIFICATIONS FOR USE ON PUBLIC ROADS, STREETS, HIGHWAYS, OR THOROUGHFARES AND HAVE READ AND HAVE AN UNDERSTANDING OF ALL THE INSTRUCTIONS FOR SAFE ASSEMBLY AND OPERATION AS WELL AS THE INSTRUCTIONS GOVERNING THE ENGINE AND OTHER PORTIONS OF THE VEHICLE.

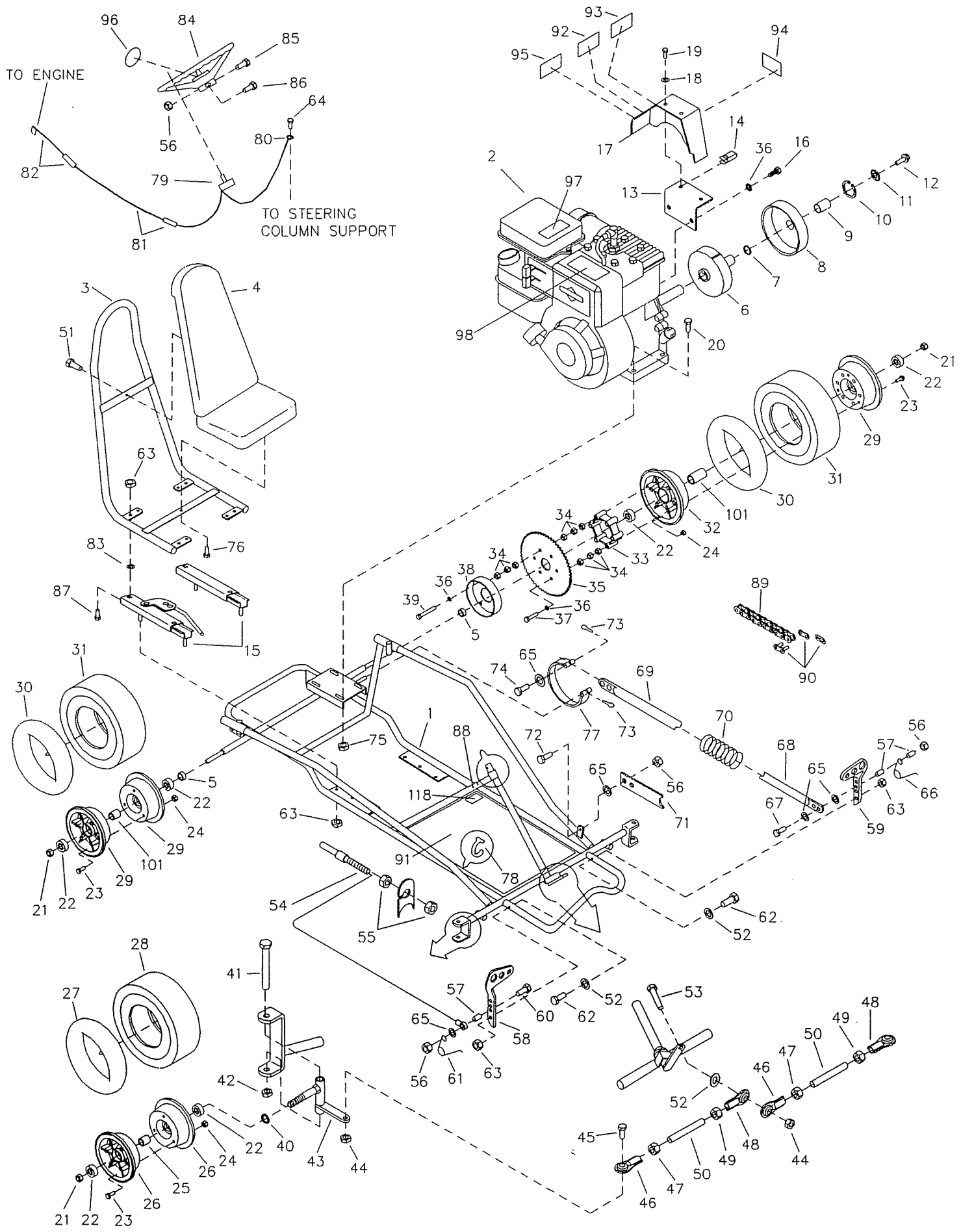

REPAIR PARTS - MODEL 405-20/-26

REF NO.	PART NO.	DESCRIPTION	REF NO.	PART NO.	DESCRIPTION
1	8215-19	Frame, 405-20 ONLY	53	9145	Bolt, 3/8-16 x 1-3/4"
	8125-18	Frame, 405-26 ONLY	54	1390	Throttle Cable w/ Housing (inc. REF 55)
2	6010	Engine, 5hp	55	9058	Nut, 5/16-24 Jam
3	9973-2	Seat Frame	56	9057	Nut, 1/4-20 Toplock
4	4324	Seat Pad	57	1389	Bushing
5	1119	Spacer, 5/8 ID x 1/8"	58	1437	Pedal, Throttle
ASM	4335	Clutch Assembly (inc. REF 6-10)	59	1436	Pedal, Brake
6	4496	Clutch Rotor	60	1847	Bolt, 1/4-20 x 1"
7	3146	Washer, Fiber	61	9502	Spring, Left Wound
8	4491	Drum w/ Sprocket (inc. REF 9)	62	9110	Bolt, 3/8 x 7/8 Shldr., 5/16-18 x 5/8 Thd.
9	3143	Bushing	63	1189	Nut, 5/16-18 Toplock
10	3141	Snap Ring	64	9796	Screw, 12-24 x 1/2" Self Tapping
11	9001	Washer, 3/8 Int/Ext Lock	65	1854	Washer, #14 Flat
12	1491	Bolt, 5/16-24 x 3/4"	66	9503	Spring, Right Wound
13	3363-2	Bracket, Chainguard	67	1849	Bolt, 1/4-20 x 1-1/2"
14	5135	Clip Nut	68	9945-2	Brake Rod, Front
15	6734	Seat Slide Pair	69	9946-2	Brake Rod, Rear
16	9101	Bolt, 5/16-24 x 1/2"	70	9709	Spring
17	3362	Chainguard	71	1982	Pedal Latch
18	6039	Washer, #10 Lock	72	1846	Bolt, 1/4-20 x 3/4"
19	6046	Screw, #10-24 x 1/2"	73	9116	Cotter Pin
20	9186	Bolt, 5/16-18 x 1-1/2"	74	9118	Clevis Pin
21	1046	Nut, 5/8-11 Toplock	75	1263	Nut, 5/16-18 Flange
ASM	8117	Front Wheel Assembly (inc. REF 22-28)	76	1876	Bolt, 1/4-20 x 5/8" Whiz Flange
ASM	9342	idle Wheel Asm (inc. REF 22-25,29-31)	77	1036	Brake Band
ASM	8104	Drive Wheel Asm (inc. REF 22-25,29-39)	78	1019	Ty-Wrap
22	1093	Bearing	ASM	9799	Stop Switch Assembly (inc. REF 79-81)
23	5839	Bolt, 1/4-20 x 3/4"	79	1392	Stop Switch
24	1186	Nut, 1/4-20	80	1393	Ring Terminal
25	5949	Spanner, 1-13/16"	81	1394	Wire, 50" w/ Splice Connector
26	8004	Wheel Half, Front 5"	82	1406	Wire w/ Blade Terminal
27	1753	Tube, Front 5"	83	9989	Washer, Retaining
28	9982	Tire, Front 4.10/3.50 x 5" Block	84	6038	Steering Wheel
29	1092	Wheel Half, Rear 6" Untapped	85	9080	Bolt, 1/4-20 x 2-3/4"
30	3802	Tube, Rear 6"	86	9160	Bolt, 1/4-20 x 7/8"
31	4915	Tire, Rear 145/70 x 6" Knobby	87	9990	Carriage Bolt, 5/16-18 x .625, Rd. Head
32	1095	Wheel Half, Rear 6" Tapped	88	1463	Bushing, Insulating
33	8008	Spacer	89	9978	Chain, #35 x 68 Pitch (inc. REF 90)
34	2388	Nut, 3/8-24	90	1269	Master Link, #35 Chain
35	9986	Sprocket, #35 Chain x 80 Teeth	91	4342	Decal, Floor Pan 405-20
36	9030	Washer, 5/16 Lock		6221	Decal, Floor Pan 405-26
37	9051	Bolt, 5/16-18 x 3"	92	1049	Decal, Caution
38	1246	Brake Drum	93	4912	Decal, Warning
39	9988	Bolt, 5/16-18 x 4"	94	6791	Decal, Oil Clutch
40	1937	Spacer, 5/8 ID x 1/4" Thick	95	6625	Decal, Tire Pressure
41	1264	Bolt, 1/2-13 x 3-1/2"	96	3296	Decal, Steering Wheel Cntr 405-20/-26
42	1012	Nut, 1/2-13 Toplock	97	9677	Decal, Hot Surfaces
43	8021	Spindle, Right Side	98	9678	Decal, Warning: Engine Exhaust
NI	8020	Spindle, Left Side	99	9679	Decal, No Riders Allowed
44	9085	Nut, 3/8-16 Toplock	100	8138	Decal, Warning: Entanglement
45	9146	Bolt, 3/8-16 x 1-1/2"	101	5950	Spanner, 2-1/8"
ASM	4355	Tie Rod Assembly (inc. REF 46-50)	102	9554-19	Rear Bar, 405-20
46	1414	Tie Rod End, Right Hand Thread		9554-18	Rear Bar, 405-26
47	9092	Nut, 3/8-24 Jam, Right Hand Thread	103	9540-2	Front Bar
48	1415	Tie Rod End, Left Hand Thread	104	9549-2	Rear Upright Bar
49	9024	Nut, 3/8-24 Jam, Left Hand Thread	105	9547-2	Center Bar
50	4352	Tie Rod	106	6320	Headrest Pad
51	9006	Bolt, 1/4-20 x 1/2" Whiz Flange	107	6452	Bolt, 3/8-16 x 5"
52	9091	Washer, 3/8 Flat	108	2386	Bolt, 3/8-16 x 3-1/2"

REPAIR PARTS - MODEL 405-20/-26

REF NO.	PART NO.	DESCRIPTION
109	2264	Bolt, 5/16-18 x 3/4"
110	9776	Clamp, Foam Stop, 3/4"
111	9759B	Foam, Side Bar, 30"
112	9758Y	Foam, Front Bar, 43" 405-20
	9758W	Foam, Front Bar, 43" 405-26
113	9763Y	Foam, 16" 405-20
	9763W	Foam, 16" 405-26
114	9764Y	Foam, 15" 405-20
	9764W	Foam, 15" 405-26
115	9765Y	Foam, 14" 405-20
	9765W	Foam, 14" 405-26
116	9800	Arm Pad Cover, 405-20
	9797	Arm Pad Cover, 405-26
117	6540	Decal, Warning: Wear Helmet
118	8154	Decal, Age Restriction
NI	9798Y	Foam Kit, Universal 405-20
	9798W	Foam Kit, Universal 405-26
NI	4350	Vehicle Operator's Manual
NI	2601	Engine Owner's Manual
NI	9212R4	Assembly Instructions
NI	5964	Decal, Oil Warning

ASM = Assembly
 NI = Not Illustrated

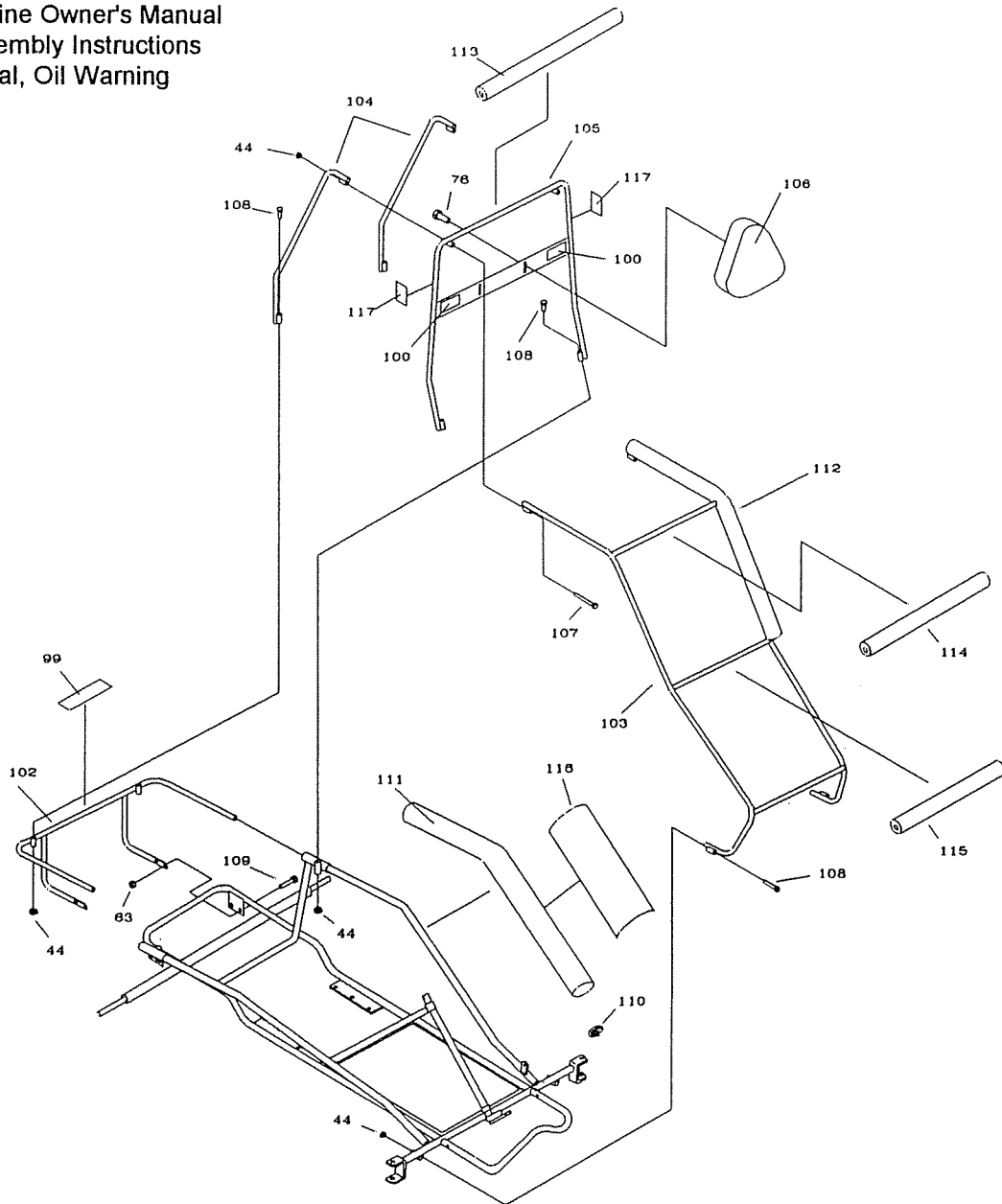

R
N
AS
1
1
1
1
1
1
1
1
1
2
2
AS
AS
AS
2
2
2
2
2
2
2
2
3
3
3
3
3
3
3
3
3
3
4
4
4
4
4
N
4
4
AS
4
4
4
4
4
5
5
5
5

THROTTLE CABLE INSTALLATION

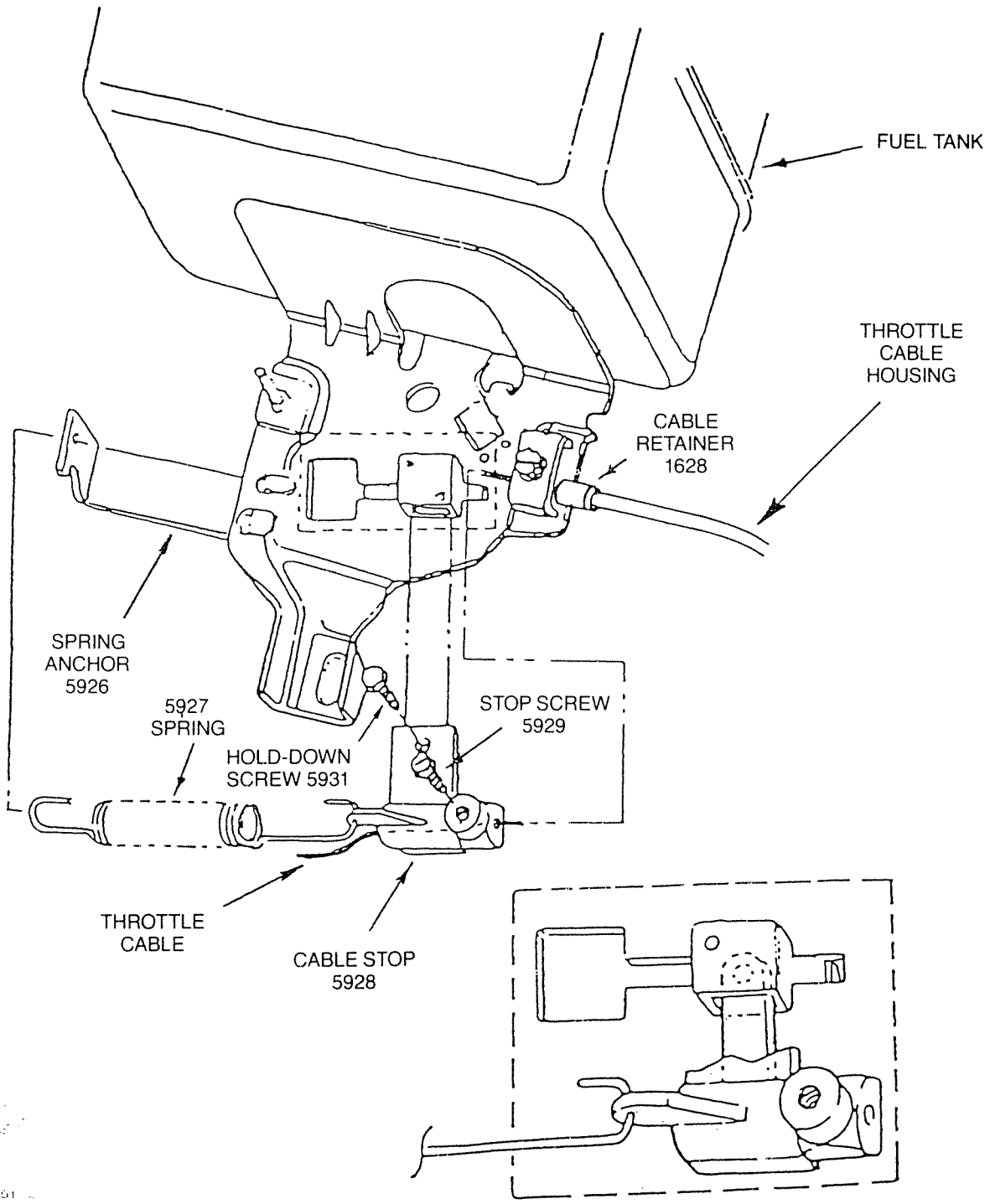

- ASSEMBLY:** Pass the throttle cable through the cable retainer and butt the throttle cable housing end against the inside shoulder of the cable retainer. (The cable retainer is to be securely fastened to the engine with the clamping screw.) Pass the end of the Throttle Cable through the hole in the cable stop. Before tightening cable stop screw:
1. Ensure spring anchor, spring, and cable are installed as illustrated above.
 2. Ensure throttle pedal is in rearward (idle) position.
 3. Ensure that there is no slack in the throttle cable with *no* tension applied to return spring.
 4. Ensure cable housing is inside and against the cable retainer.