

SECTION 1 - FRAME GROUP

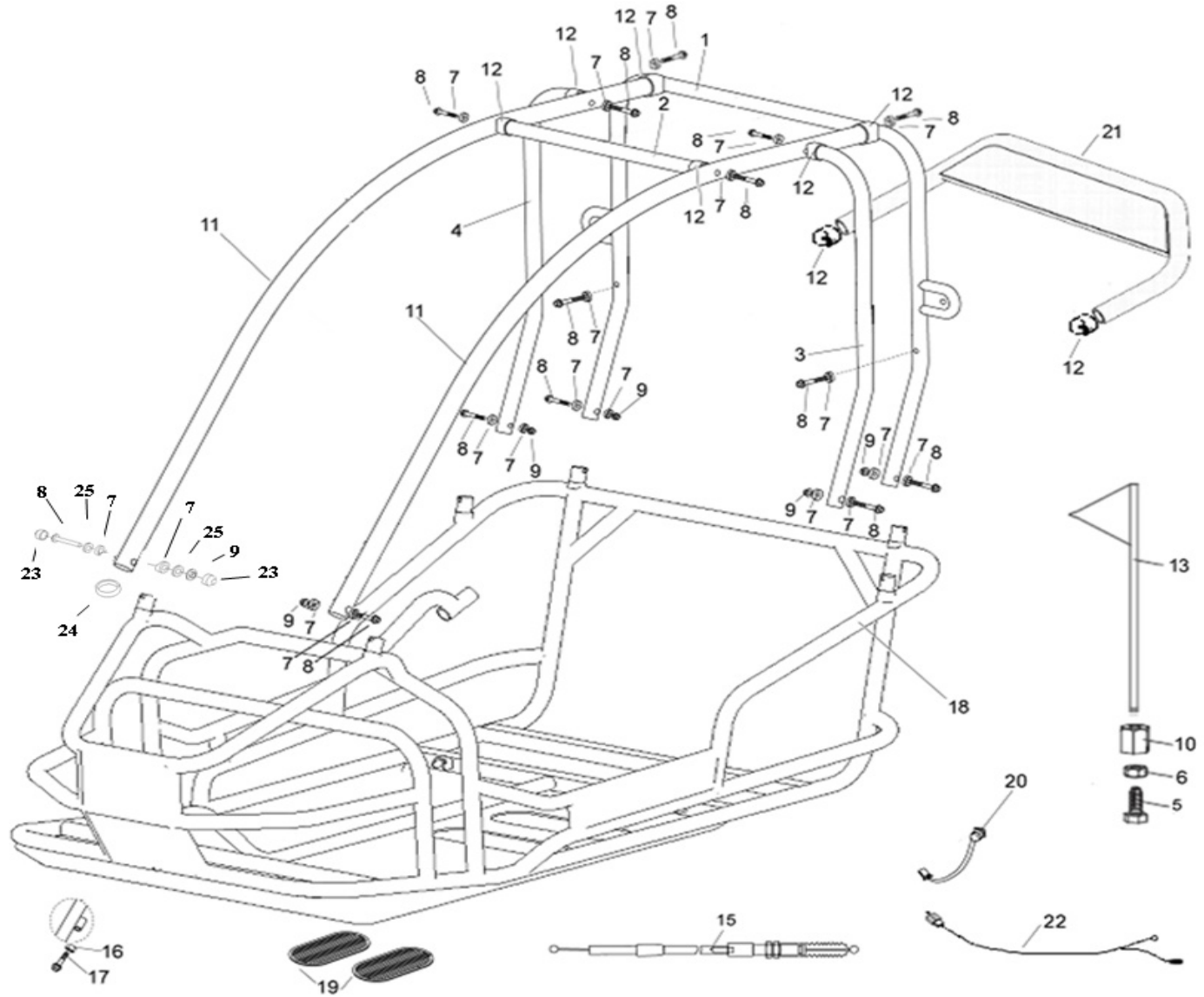

REF. #	PART #	DESCRIPTION	QTY.
1	14787-20	BAR, REAR C PILLAR - 3171 - YELLOW	1
	14787-2	BAR, REAR C PILLAR - 3170 - BLACK	
2	14795-20	BAR, OH CROSS - 3171 - YELLOW	1
	14795-2	BAR, OH CROSS - 3170 - BLACK	
3	14603-20	BAR, LH B PILLAR - 3171 - YELLOW	1
	14603-2	BAR, LH B PILLAR - 3170 - BLACK	
4	14604-20	BAR, RH B PILLAR - 3171 - YELLOW	1
	14604-2	BAR, RH B PILLAR - 3170 - BLACK	
5	14465	BOLT, M12 X 1.75 X 30 FLAG MOUNT	1
6	14492	NUT, M12 X 1.25 HEX ZN	1
7	14087	WASHER, 8M CONCAVE CLAMP ZN	20
8	14247	BOLT, M8 X 1.25 X 45 FHCS ZN	14
9	14088	NUT, M8 X 1.25 LOCKING FLANGE ZN	6
10	14466	NUT,1.75 THREAD DECORATIVE PLSTC FLG MNT	1
11	14607-20	BAR, OH FRONT - 3171 - YELLOW	2
	14607-2	BAR, OH FRONT - 3170 - BLACK	
12	14084	ENDCAP, BAR - 1.00 BLACK PLASTIC	8
13	14464	FLAG, SAFETY - SLI	1
15	14609	CABLE, THROTTLE	1
16	14610	NUT, M8 X 1.25	1
17	14437	BOLT, M8 X 1.25 X 25 HHCS ZN	1
18	15050-2	FRAME, 3171 - BLACK	1
	15050-47	FRAME, 3171 - SILVER	
19	14612	PAD, RUBBER FOOT	2
20	14789	STOP SWITCH - 3170	1
21	14790-20	SPOILER, 3170 - YELLOW	1
	14790-47	SPOILER, 3171 - SILVER	
22	14791	HARNESS, WIRING - 3170	1
23	14945	COVER, BOLT CAP - 1.5 IN	20
24	15052	SEAL, CONNECTOR - RUBBER	6
25	14944	WASHER, BAR CONNECTION	20

SECTION 2 - INTERIOR

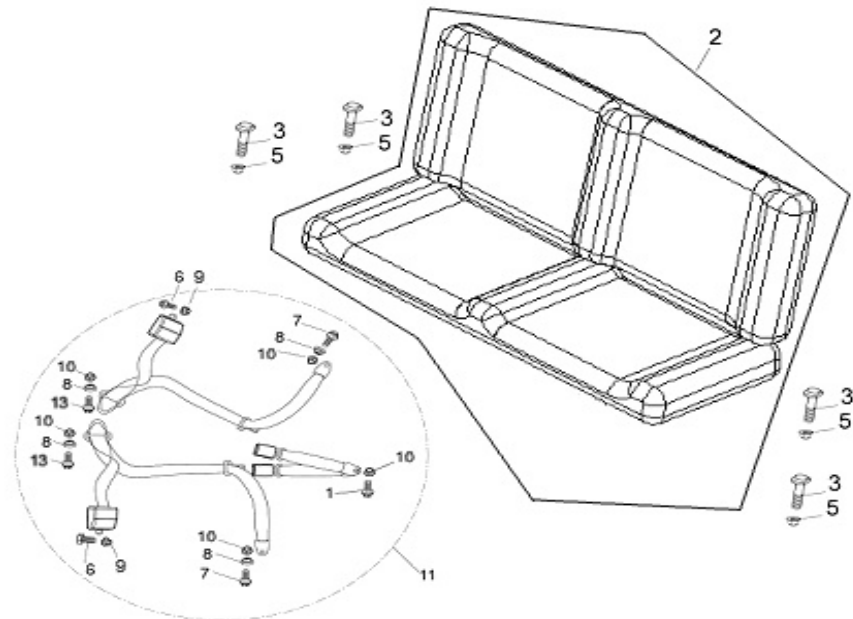



REF. #	PART #	DESCRIPTION	QTY.
1	14686	BOLT, M10 X 1.25 X 30	1
2	15053	SEAT, BLACK VINYL BENCH - 3171B	1
3	14435	BOLT, M8 X 1.00 X 22 FHCS DAC	4
5	14088	NUT, M8 X 1.25 LOCKING FLANGE ZN	4
6	14451	BOLT, M12 X 1.25 X 25 FHCS ZN	2
7	14687	BOLT, M10 X 1.25 X 20 ZN	2
8	14289	WASHER, M12 FLAT ZN	4
9	14324	NUT, M12 X 1.25 LOCKING FLANGE ZN	2
10	14243	NUT, M10 X 1.25 LOCKING FLANGE ZN	5
11	8778	SEATBELT, RETRACTABLE W/ SLEEVE	2
13	82073	BOLT M10 X 1.25 X 25	2

SECTION 3 - FRONT SUSPENSION

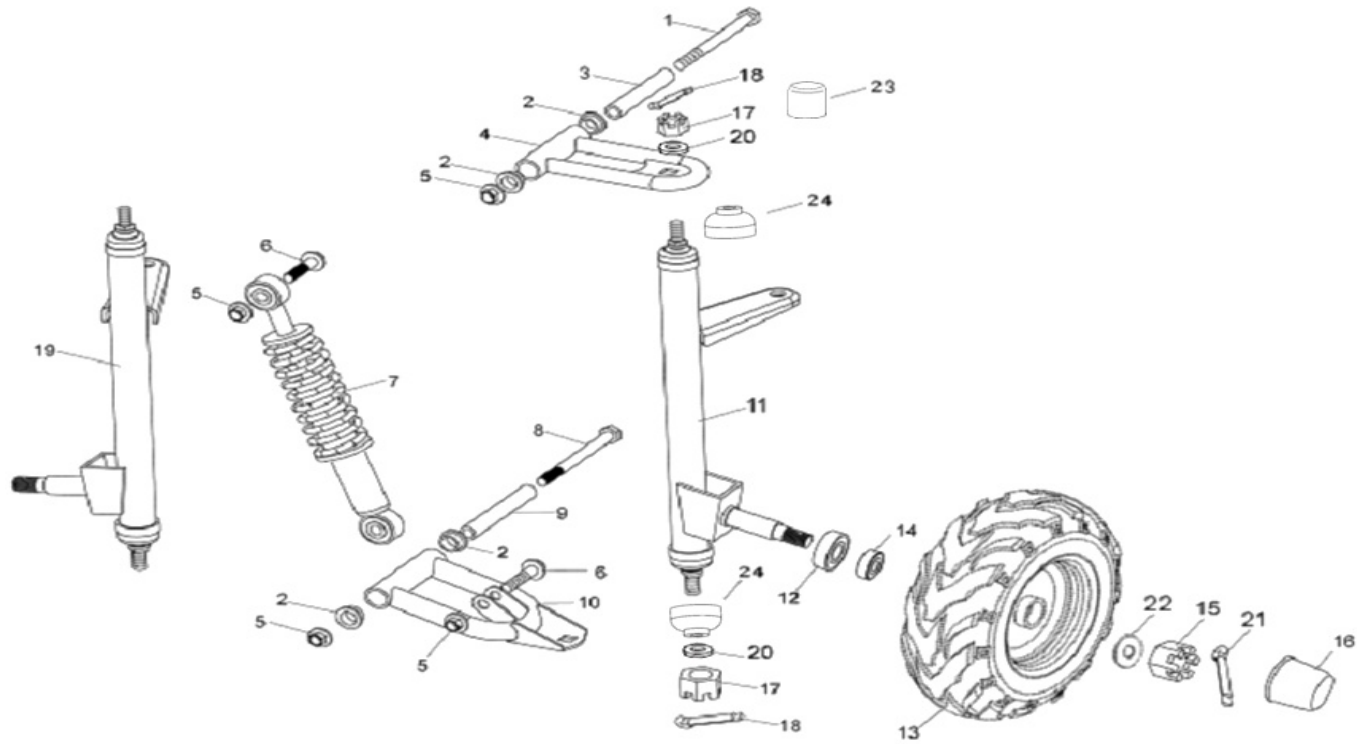

REF. #	PART #	DESCRIPTION	QTY.
1	14615	BOLT, M8 X 1.25 X 95 FLANGE	2
2	14126	BUSHING, FLANGED SLEEVE 12 X 16 X 12	8
3	14617	UPPER SUSPENSION ARM COLLAR, 75MM	2
4	14618-20	UPPER SUSPENSION ARM - 3170 - YELLOW	2
	14618-47	UPPER SUSPENSION ARM - 3171 - SILVER	
5	14088	NUT, M8 X 1.25 LOCKING FLANGE ZN	8
6	14246	BOLT, M10 X 1.25 X 40 FHCS ZN	4
7	14793	SHOCK, FRONT BLACK	2
8	14620	BOLT, M8 X 1.25 X 105	2
9	14621	LOWER SUSPENSION ARM COLLAR, 85MM	2
10	14622-20	LOWER SUSPENSION ARM ASSY 3170 - YELLOW	2
	14622-47	LOWER SUSPENSION ARM ASSY 3171 - SILVER	
11	14623-2	SPINDLE AND STRUT SUPPORT, R 3170 - BLK	1
12	14624	BEARING 6003Z	2
13	14794	ASM, TIRE/WHEEL FRONT 145/70-6 - 3170	2
14	14626	BEARING 6201	2
15	14244	NUT, M12 X 1.25 CASTLE ZN	2
16	14627	HUB COVER, FRONT 36MM ID	2
17	14242	NUT, M10 X 1.25 CASTLE	4
18	14628	PIN, M1.6 X 15 COTTER	4
19	14629-2	SPINDLE AND STRUT SUPPORT, L 3170 - BLK	1
20	14241	WASHER, M10 SPLIT LOCK ZN	4
21	14150	PIN, M2 X 20 COTTER	2
22	14316	SPACER, M15 INNER GEAR - 150CC	2
23	14923	CAP, NUT COVER RUB - BLK -3170/4170	2
24	14857	SEAL, BALL JOINT - 31XX/41XX	4

SECTION 4 - STEERING ASSEMBLY

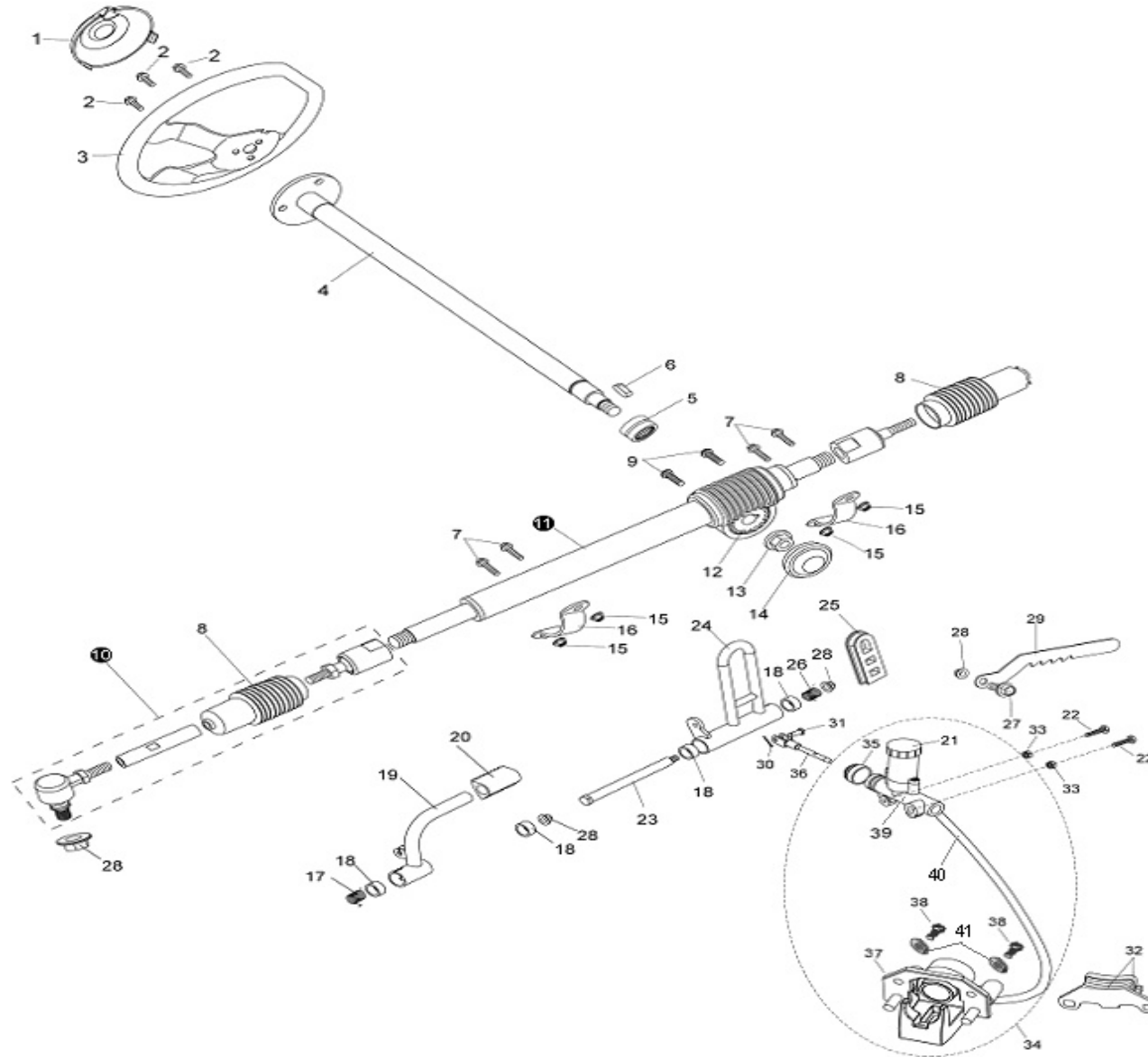

REF. #	PART #	DESCRIPTION	QTY.
1	14631	COVER, STEERING WHEEL - 31X/41X	1
2	14426	BOLT, M6 X 1.00 X 14 FHCS ZN	3
3	14632	STEERING WHEEL - 31X/41X	1
4	14633-2	SHAFT, STEERING - 3170 - BLACK	1
5	14634	BEARING, 18 X 16	1
6	14635	KEY, 4 X 4 X 11.5	1
7	14341	BOLT, M6 X 1.00 X 20 FHCS ZN	4
8	14636	STEERING BALL JOINT DUST COVER	2
9	14565	SCREW, M5 X 12 PH	2
10	14637	ASM, TIE ROD END - 31X/41X - BLACK	2
11	14638	STEERING SHAFT, PLASTIC HOUSING	1
12	14639	STEERING GEAR	1
13	14243	NUT, M10 X 1.25 LOCKING FLANGE ZN	1
14	14641	DUST COVER	1
15	14236	NUT, M6 X 1.00 NYLOC FLANGE ZN	4
16	14642-2	STEERING GEAR BRACKET (R.S.B.) - BLACK	2
17	14643	SPRING, THROTTLE PEDAL	1
18	14119	BUSHING, SLEEVE 12 X 21 X 12	4
19	14645-2	PEDAL, THROTTLE - 3171 - BLACK	1
20	14526	CAP, THROTTLE PEDAL - 31X/41X/61X	1
21	14646	CAP, BRAKE MASTER CYLINDER	1
22	14647	BOLT, M6 X 1.0 X 25 ZN	2
23	14648	BOLT, M8 X 1.25 X 144 HHCS	1
24	14649-2	PEDAL, BRAKE - 3171 - BLACK	1
25	14650	PAD, BRAKE PEDAL - 31X/41X - BLACK	1
26	14651	SPRING, BRAKE PEDAL	1
27	14239	BOLT, M8 X 1.25 X 20 FHCS ZN	1
28	14088	NUT, M8 X 1.25 LOCKING FLANGE ZN	3
29	14652	LEVER, PARKING BRAKE - 31X/41X	1
30	14628	PIN, M1.6 X 14 COTTER	1
31	14653	STUD, 6 X 16	1
32	14654	KIT, BRAKE PAD - 31X/41X	1
33	14236	NUT, M6 X 1.00 NYLOC FLANGE ZN	2
34	14655	ASM, HYDRAULIC BRAKE	1
35	14656	BOOT, BRAKE	1
36	14657	SHAFT, BRAKE MASTER CYLINDER	1
37	14658	ASM, BRAKE CALIPER - 31X/41X	1
38	14455	BOLT, M8 X 1.25 X 14 SHCS PL	2
39	14744	MASTER CYLINDER, BRAKE - 31X/41X (RESERVOIR AND CAP INCLUDED)	1
40	14130	HOSE, HYD BRAKE - 75"	1
41	14748	WASHER, M8 SPLIT LOCK	2

SECTION 5 - REAR SWING ARM

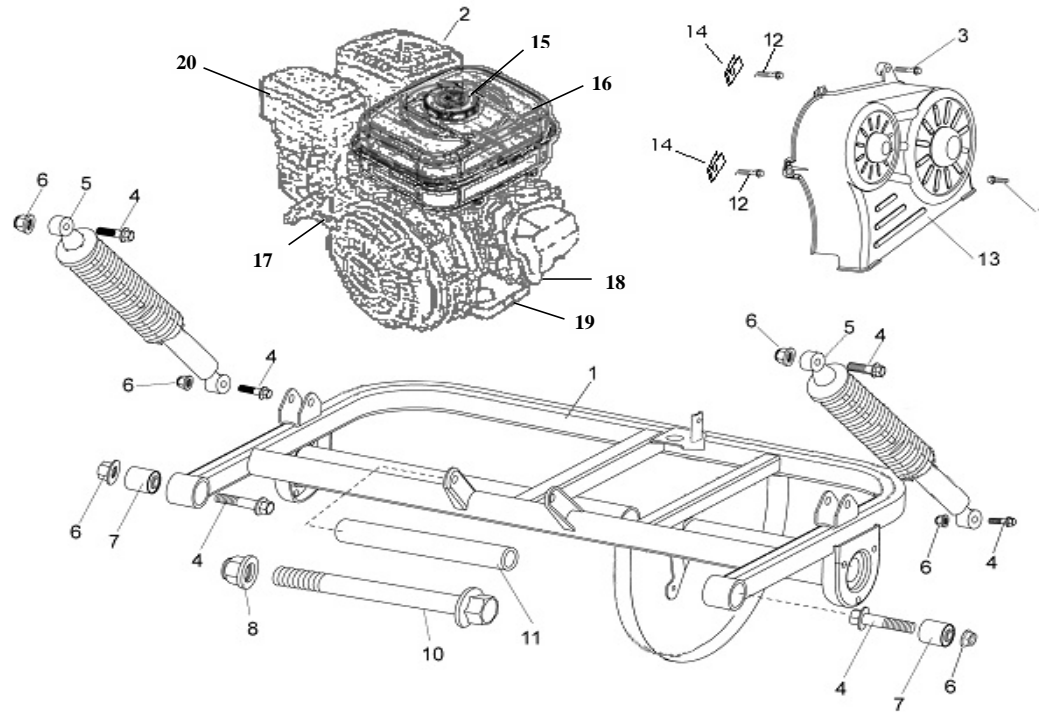

REF. #	PART #	DESCRIPTION	QTY.
1	14799-2	ASM, REAR SWINGARM - 3170 - BLACK	1
2	15018	ENGINE, LCT 136CC W/TANK	1
3	14341	BOLT, M6 X 1.00 X 20 FHCS ZN	1
4	14246	BOLT, M10 X 1.25 X 40 FHCS ZN	6
5	14796	SHOCK, REAR 3170 - RED & BLACK	2
6	14243	NUT, M10 X 1.25 LOCKING FLANGE ZN	6
7	14661	BUSHING, SWINGARM ISOLATOR - 150CC	2
8	14243	NUT, M10 X 1.25 LOCKING FLANGE ZN	1
9	14778	SCREW, M4 X 1.75 X 12 PH	1
10	14662	BOLT, M10 X 1.25 X 174 HHCS	1
11	14666	SPANNER	1
12	9006	BOLT 1/4-20 X .500 HH WF	2
13	15054	COVER, DRIVE - 3171 - PLASTIC	1
14	8227	NUT 1/4-20 CLIP	2
15	15055	CAP, FUEL - LCT 136CC	1
16	15056	TANK, FUEL - LCT 136CC	1
17	15057	SPARK PLUG, TORCH F6RTC	1
18	15058	DIPSTICK, OIL - LCT 136CC	1
19	15059	PLUG, OIL DRAIN - LCT 136CC	1
20	15060	FILTER, AIR - LCT 136CC	1

SECTION 6 - JACKSHAFT

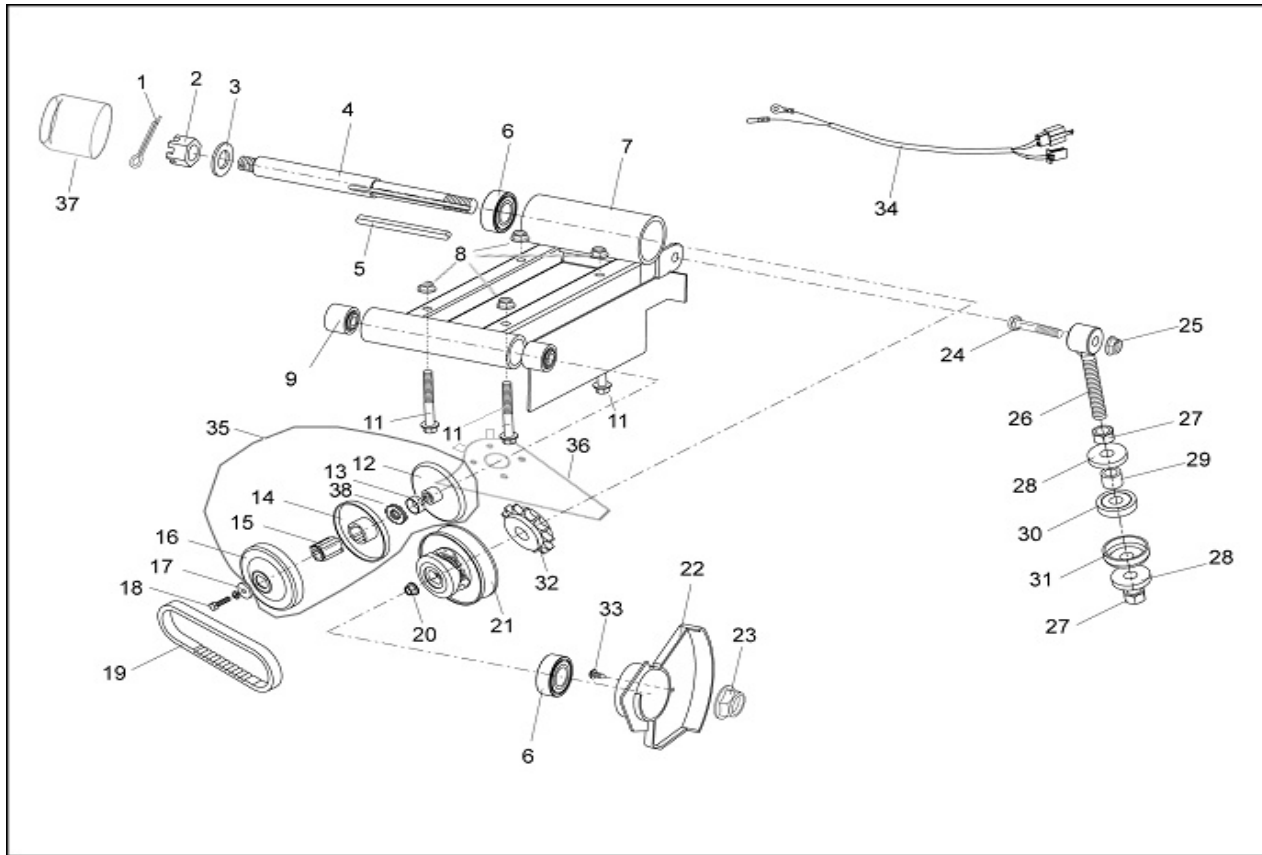

REF. #	PART #	DESCRIPTION	QTY.
1	14150	PIN, M2 X 20 COTTER	1
2	14727	NUT, M14 X 1.25 CASTLE	1
3	14690	WASHER, M12 ZN	1
4	14691	SHAFT, SPROCKET & DRIVEN PULLEY	1
5	14692	KEY	1
6	14693	BEARING	2
7	14800-2	ENGINE MOUNTING PLATE - BLACK	1
8	14088	NUT, M8 X 1.25 LOCKING FLANGE ZN	4
9	14695	BUSHING	2
11	14697	BOLT, M8 X 1.25 X 60 FHCS	4
12	14698	SHEAVE, STATIONARY	1
13	14699	BUSHING	1
14	14700	SHEAVE, MOVEABLE	1
15	14701	HUB	1
16	14702	DRUM	1
17	14703	WASHER, M8	1
18	1454	BOLT 5/16-24 X 1.750 HHCS G5	1
19	5959	BELT	1
20	14705	NUT, M16 X 1.25 LOCKING FLANGE	1
21	14706	DRIVEN PULLEY	1
22	15061	GUARD, REAR CHAIN - 3171 - BLACK PLASTIC	1
23	9101	BOLT 5/16-24 X .500 HHCS G5 NL Z	2
24	14446	BOLT, M10 X 1.25 X 45 FHCS ZN	1
25	14243	NUT, M10 X 1.25 LOCKING FLANGE ZN	1
26	14708	CHAIN ADJUSTER	1
27	14709	NUT, M12	2
28	14710	WASHER - CHAIN ADJUSTER	2
29	14469	SPACER, ENGINE ADJ ALIGNMENT - 150CC	1
30	14467	BUSHING, ENGINE ADJ ISOLATOR - 150CC	1
31	14468	SPACER, ENGINE ADJ CUP - 150CC	1
32	14714	SPROCKET, 10T DRIVEN	1
33	14423	SCREW, M5 X 16 PHSM ZN	1
34	14324	NUT, M12 X 1.25 LOCKING FLANGE ZN	1
35	14716	DRIVER PULLEY	1
36	15062	PLATE, BACK - 3171 (WITH TABS)	1
37	14723	CAP, JACKSHAFT 2 IN	1
38	14838	WASHER - SPEED REDUCTION	1

SECTION 7 - REAR AXLE

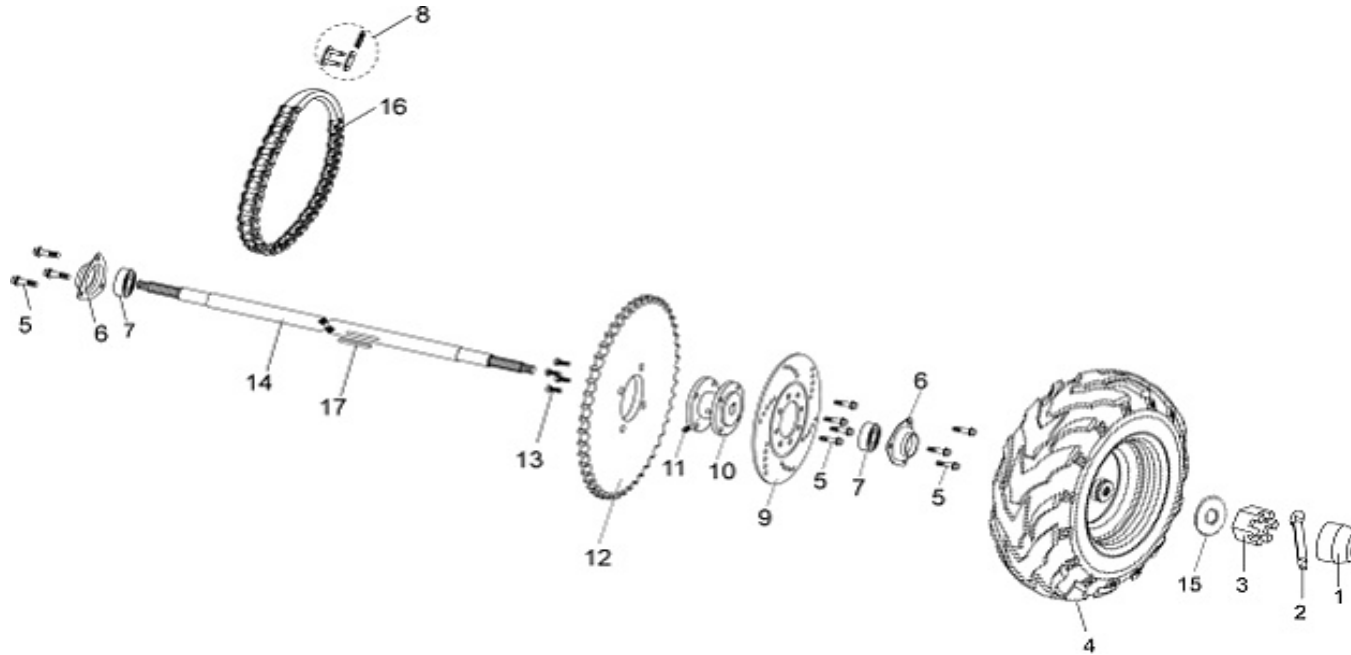



REF. #	PART #	DESCRIPTION	QTY.
1	14627	CAP, HUB NOSE - BLACK	2
2	89018	COTTER PIN 3.2 X 30	2
3	14249	NUT, M16 X 1.5 CASTLE	2
4	14797	ASM, TIRE/WHEEL REAR 16 X 8.0-7 - 3170	2
5	14434	BOLT, M8 X 1.25 X 16 FHCS ZN	10
6	14668	FLANGE BEARING - 150CC	2
7	14593	BEARING 6005Z	2
8	14669	MASTER LINK	1
9	14670	DISK, REAR BRAKE - 150CC	1
10	14671	SPACER, SPROCKET	1
11	14769	SCREW, SET M8 X 1.25 X 14 SHCS PL	1
12	14672	SPROCKET	1
13	14434	BOLT, M8 X 1.25 X 16 FHCS ZN	4
14	14798	AXLE - 3170	1
15	14724	WASHER, 29.5 X 17MM X 3.0 ZN	2
16	14675	CHAIN	1
17	14676	KEY, 5 X 5 X 75	1