

Operator's Manual SUPPLEMENT

MODEL NO. 225

WARNING:
Read Engine
Owner's Manual,
Vehicle Operator's
Manual, and
Supplement
Carefully Before
Operating
Vehicle.

**Parts List
Assembly**

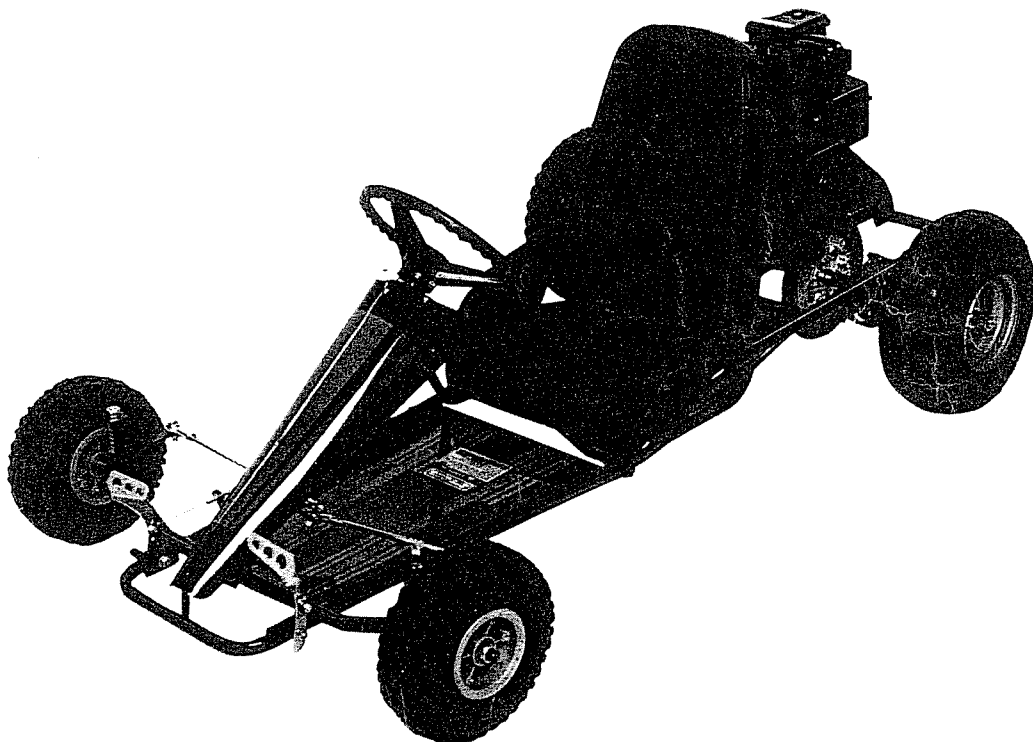

**THIS VEHICLE IS FOR
OFF-ROAD USE ONLY**

BEFORE OPERATING THIS VEHICLE, THE OWNER AND/OR OPERATOR MUST UNDERSTAND THE VEHICLE WAS NOT DESIGNED OR MANUFACTURED TO MEET SPECIFICATIONS FOR USE ON PUBLIC ROADS, STREETS, HIGHWAYS, OR THOROUGHFARES AND HAVE READ AND HAVE AN UNDERSTANDING OF ALL THE INSTRUCTIONS FOR SAFE ASSEMBLY AND OPERATION AS WELL AS THE INSTRUCTIONS GOVERNING THE ENGINE AND OTHER PORTIONS OF THE VEHICLE.

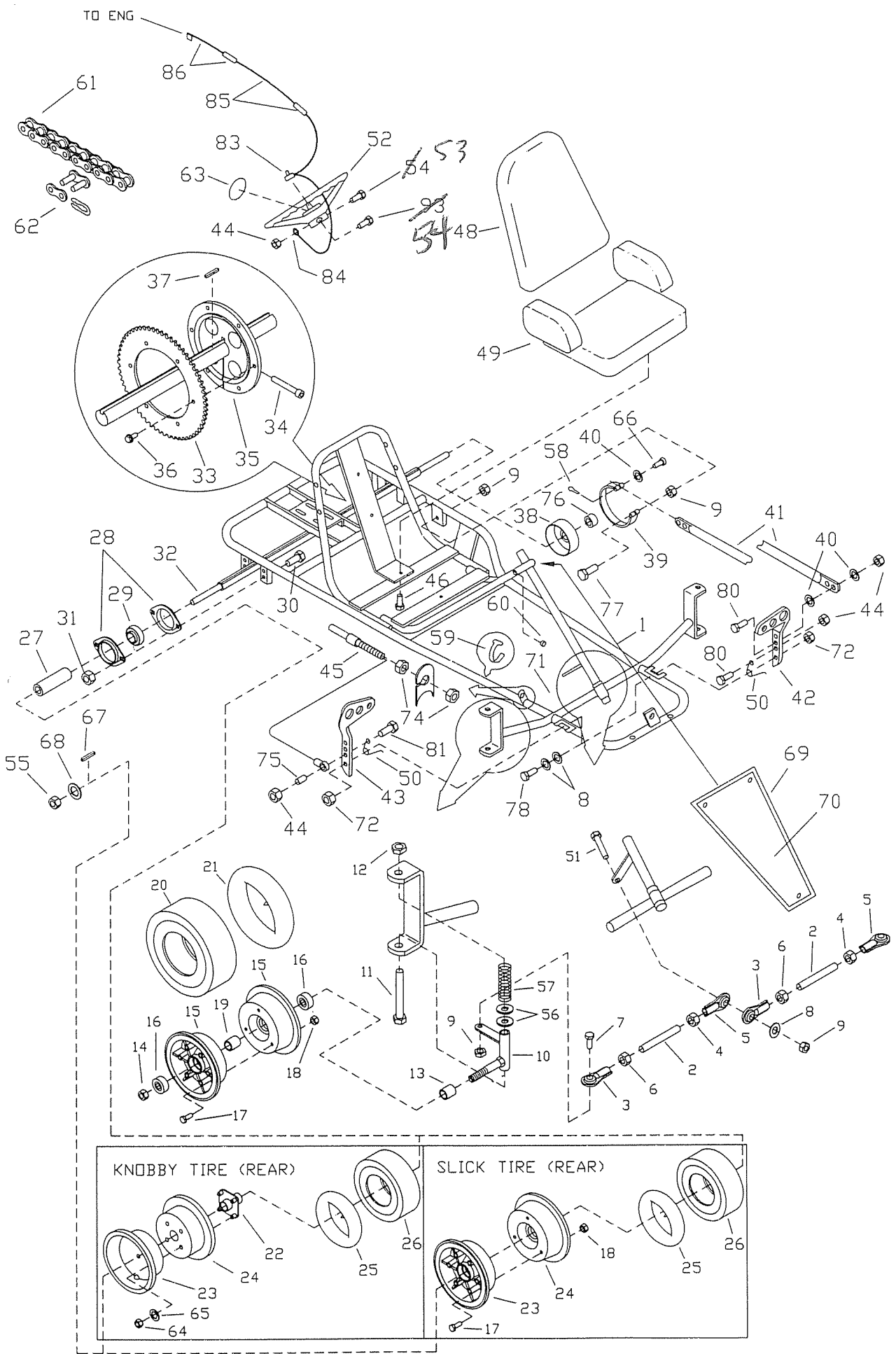

REPAIR PARTS

MODEL 225

REF NO.	PART NO.	DESCRIPTION	REF NO.	PART NO.	DESCRIPTION
		<i>30291</i>			
1	3092-2	Frame	45	1390	Throttle Cable
ASM	1464	Tie Rod Assembly (inc. #2-6)	46	9006	Bolt, 1/4-20 x 1/2" Flange
2	1465	Tie Rod	48	5159	Seat Back
3	1415	Rod End - Left Hand Thread	49	5160	Seat Bottom
4	9092	Nut, 3/8-24 Right Hand Thread	50	6980	Pedal Return Spring
5	1414	Rod End - Right Hand Thread	51	9145	Bolt, 3/8-16 x 1-3/4"
6	9024	Nut, 3/8-24 Left Hand Thread	52	6038	Steering Wheel
7	9146	Bolt, 3/8-16 x 1-1/2"	53	9080	Bolt, 1/4-20 x 2-3/4"
8	9091	Washer, 3/8 Flat	54	9160	Bolt, 1/4-20 x 7/8" with Nylock
9	9085	Nut, 3/8-16 Lock	55	9052	Nut, 3/4-16 Toplock
10	9307-2	Spindle - Right Side	56	9022	Washer, 1/2" Flat
NI	9308-2	Spindle - Left Side	57	5681	Spring
11	5682	Bolt, 1/2-13 x 5-1/2"	58	9116	Cotter Pin
12	1012	Nut, 1/2-13 Toplock	59	1019	Ty-Wrap
13	1104	Spacer, 5/8" x 3/4"	60	1463	Bushing, Plastic
14	1046	Nut, 5/8-11 Toplock	61	6021 (SL)	Chain, #35 x 79P w/ Mstr Link
ASM	4553 (SL)	Front Wheel Asmbly (inc. #15-21)		6021D (KN)	Chain, #35 x 87P w/ Mstr Link
	2497 (KN)	Front Wheel Asmbly (inc.#15-21)	62	1269	Master Link, #35
15	5158	Wheel Half - 4"	63	3296	Decal, Steering Wheel
16	1093	Bearing	64	2388	Nut, 3/8-24
17	5839	Bolt, 1/4-20 x 3/4"	65	1130	Washer, 3/8 Split Lock
18	1186	Nut, 1/4-20 Whiz	66	9118	Clevis Pin, 1/4"OD x 1-1/4"
19	5949	Spanner	67	6123	Key, 1/4" Square x 1-3/4"
20	1751 (SL)	Tire, 4.10 x 3.50 x 4" Slick	68	1194 (KN)	Washer, 3/4" Flat
	2244 (KN)	Tire, 4.10 x 3.50 x 4" Knobby	ASM	2693	Custom Cover Asmbly (inc. #69-70)
21	1053	Tube, 4"	69	2257	Custom Cover
ASM	6099 (SL)	Rear Wheel Asmbly (inc. #23-26)	70	6105	Decal, Custom Cover
	6279P (KN)	Rear Wheel Asmbly (inc. #22-26)	71	6104	Decal, Floor Pan
22	4927 (KN)	Hub	72	1263	Nut, 5/16-18 Flange Whiz
23	5128 (SL)	Wheel Half, 5" Inside	74	9058	Nut, 5/16-24 Jam
	4925 (KN)	Wheel Half, 6" Inside	75	1389	Bushing
24	5127 (SL)	Wheel Half, 5" Outside	76	1082	Spacer, 1"ID x 7/16"
	4926 (KN)	Wheel Half, 6" Outside	77	1449	Bolt, 3/8-16 x 2"
25	1753 (SL)	Tube, 5"	78	1447	Bolt, 5/16-18 x 1-3/4" Shoulder
	3802 (KN)	Tube, 6"	80	1846	Bolt, 1/4-20 x 3/4"
26	6035 (SL)	Tire, 4.10 x 3.50 x 5" Slick	81	1847	Bolt, 1/4-20 x 1"
	4915 (KN)	Tire, 145/70 x 6" Knobby	ASM	1391	Stop Switch Asm (inc. #83-85)
27	2069 (SL)	Spacer, 1" ID x 2-7/8"	83	1392	Stop Switch
	5646 (KN)	Spacer, 1" ID x 2-1/4"	84	1393	Ring Terminal
28	1760	Bearing Flange	85	1394	Wire, 50" with Splice Connector
29	3941	Bearing	86	1406	Wire, to Engine with Splice Cnctor
30	2264	Bolt, 5/16-18 x 3/4"	NI	1049	Warning Decal - ...Drive Cover
31	1189	Nut, 5/16-18 Toplock	NI	2832-White	Warning Decal - No Passengers
32	2253	Axle	NI	4504	Warning Decal - Yellow
ASM	5152 (SL)	Sprocket Asmbly (inc. #33-36)	NI	4912	Warning Decal - This Guard...
	2999 (KN)	Sprocket Asmbly (inc. #33-36)	NI	6621 (SL)	Decal - Tire Pressure
33	1420 (SL)	Sprocket, 60 Teeth 35 Chain		6625 (KN)	Decal - Tire Pressure
	2998 (KN)	Sprocket, 72 Teeth 35 Chain	NI	6791	Decal - Oil Clutch
34	6701	Bolt, 5/16-18 Socket Head	NI	2601	Engine Owner's Manual
35	6280	Sprocket Hub	NI	4350	Fun Kart Operator's Manual
36	1876	Bolt, 1/4-20 x 5/8" Whiz			
37	1775	Key, 1/4" Square x 1-1/4" Long			
38	1078	Brake Drum			
39	1492	Brake Band			
40	1854	Washer, #14 Flat			
41	8040	Brake Rod			
42	1436	Brake Pedal			
43	1437	Throttle Pedal			
44	9057	Nut, 1/4-20 Toplock			

ASM = Assembly
NI = Not Illustrated



NOTE: Use Part Numbers with the (SL) designation if your kart has Slick Tires or (KN) if your kart has Knobby Tires.

ENGINE ASSEMBLY REPAIR PARTS

MODEL 225

REF NO	PART NO	DESCRIPTION
1	1491	Bolt, 5/16-24 x .75"
2	9001	Washer, 3/8 Int/Ext Lock
ASM	4335	Clutch Assembly (inc. REF 3-7)
3	3141	Snap Ring
4	3143	Bearing
5	4491	Drum (inc. REF 4)
6	3146	Washer, Fiber
7	4496	Clutch Rotor
8	9101	Bolt, 5/16-24 x .5"
9	9030	Washer, 5/16 Int Lock
10	3363-2	Bracket, Chainguard
11	5135	Nut, Tinnerman
12	6010	Engine, 5HP
13	9186	Bolt, 5/16-18 x 1.5"
14	1263	Nut, 5/16-18 Flange
15	6046	Screw, 10-24 x .5"
16	6039	Washer, #10 Int Lock
17	4294	Chainguard

ASM = Assembly

